



MODEL 1084A/B/C

SATELLITE-CONTROLLED CLOCK

OPERATION MANUAL



Model 1084A

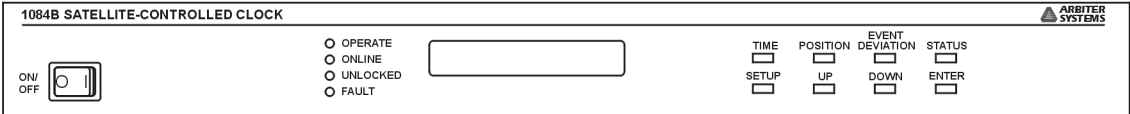

Model 1084B

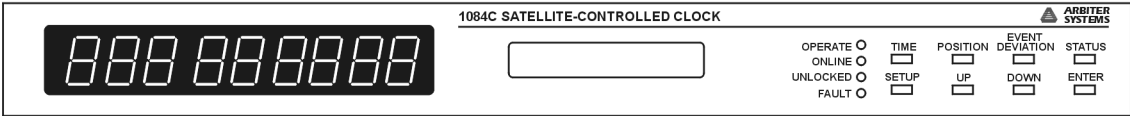

Model 1084C

Arbiter Systems, Inc.
 Paso Robles, CA 93446
 U.S.A.

Description This manual is issued for reference only, at the convenience of Arbiter Systems. Reasonable effort was made to verify that all contents were accurate as of the time of publication. Check with Arbiter Systems at the address below for any revisions made since the original date of publication.

Contact Information

Arbiter Systems, Inc.
1324 Vendels Circle, Suite 121
Paso Robles, CA 93446
(805) 237-3831
Website: www.arbiter.com
<mailto:techsupport@arbiter.com>
<mailto:sales@arbiter.com>

What This Manual Covers

This manual describes the set up and operation of the Model 1084A/B/C series satellite-controlled clocks.

ROM Dates

This version of the manual is written for these model clocks having ROM dates of 1 March 2007 or later. Any changes made in subsequent revisions which affect operation or specifications will be noted with either (a) a new manual or (b) a revised version of this manual. To display the ROM date for your instrument, press and release the SETUP key at power up and the ROM date should appear briefly.

Firmware Updates

Firmware updates are available to customers by contacting Arbiter Systems at the information given above. Where applicable, this update may include new documentation, such as a new version of this manual.

LIMITED WARRANTY

Arbiter Systems makes no warranty, expressed or implied, on any product manufactured or sold by Arbiter Systems except for the following limited warranty against defects in materials and workmanship on products manufactured by Arbiter Systems.

Products manufactured by Arbiter Systems are guaranteed against defective materials and workmanship under normal use and service from the date of delivery for the period listed as Limited Lifetime¹. The responsibility of Arbiter Systems under this warranty is limited to repair or replacement, at Arbiter Systems' option, of any product found to be defective. Arbiter Systems shall have no liability under this warranty unless it receives written notice of any claimed defect.

For warranty service or repair, products must be returned to a service facility designated by Arbiter Systems. Buyer shall prepay all shipping charges to Arbiter Systems, and Arbiter Systems shall pay shipping charges incurred in returning the product to Buyer. However, Buyer shall pay all shipping charges, duties and taxes for products returned to Buyer in a country other than the United States of America.

THE WARRANTY SET FORTH HEREIN CONSTITUTES THE ONLY WARRANTY OBLIGATIONS OF ARBITER SYSTEMS, EXPRESSED OR IMPLIED, STATUTORY, BY OPERATION OF LAW, OR OTHERWISE. ARBITER SYSTEMS DISCLAIMS ANY WARRANTY OF MERCHANTABILITY OR FITNESS FOR A PARTICULAR PURPOSE, AND BUYER EXPRESSLY WAIVES ALL OTHER WARRANTIES.

This limited warranty does not extend to any product, which has been subject to

1. Improper use or application, abuse, or operation beyond its rated capacity, or contrary to the instructions in the operation and maintenance manuals (if any);
2. Accident;
3. Repair or maintenance performed by Buyer, except in accordance with the operation and maintenance manuals, if any, and any special instructions of Arbiter Systems;
4. Modification without the prior written authorization of Arbiter Systems (whether by the substitution of non-approved parts or otherwise). The remedies provided herein are Buyer's sole and exclusive remedies. In no event shall Arbiter Systems be liable for direct, indirect, incidental or consequential damages (including loss of profits), whether based on contract, tort, or other legal theory.

FOR THE FASTEST POSSIBLE SERVICE, PLEASE PROCEED AS FOLLOWS:

1. Notify Arbiter Systems, Inc., specifying the instrument model number and serial number and giving full details of the difficulty. Service data or instrument-return authorization will be provided upon receipt of this information.
2. If instrument return is authorized, forward prepaid to the manufacturer. If it is determined that the instrument is not covered by this warranty, an estimate will be made before the repair work begins, if requested.

See Contact Information on page ii.

¹Limited Lifetime means that Arbiter Systems will repair or replace the defective component as long as components are available and for no more than five years after the product has been deemed obsolete.

Model 1084A/B/C

Satellite-Controlled Clock

Operation Manual

- Chapter 1 – Unpacking the Clock
- Chapter 2 – Front and Rear Panels
- Chapter 3 – Connecting Inlet Power, Input and Output Signals
- Chapter 4 – Antenna and Cable Information
- Chapter 5 – Setting Internal Jumpers
- Chapter 6 – The Setup Menus
- Chapter 7 – Timing, IRIG-B and Pulses
- Chapter 8 – Relay Contacts and Event Inputs
- Chapter 9 – Serial Communications and Command Set
- Chapter 10 – Startup and Basic Operation
- Appendix A – Specifications and Technical Details
- Appendix B – Using Surge Protectors
- Appendix C – Options List
- Appendix D – CE Mark Certification
- Appendix E – Statement of Compliance
- Index

Copyright Arbiter Systems Incorporated September 2007 All rights reserved. International copyright secured.

PD0016100J

Contents

| | | |
|----------|---|-----------|
| 1 | Unpacking the Clock | 1 |
| 1.1 | Introduction | 1 |
| 1.2 | Precautions | 1 |
| 1.3 | Unpacking and Locating Accessories | 1 |
| 1.4 | Attaching Rack-Mount Ears to 1084A/B/C Series Clocks | 2 |
| 1.4.1 | Mounting Instructions | 2 |
| 2 | Front and Rear Panels | 5 |
| 2.1 | Introduction | 5 |
| 2.2 | Front Panel Controls and Indicators | 5 |
| 2.2.1 | Annunciator LED Definitions | 6 |
| 2.2.2 | Command Key Definitions | 6 |
| 2.2.3 | LED Status Indicators | 7 |
| 2.2.4 | LCD Display | 7 |
| 2.2.5 | Front Panel Keys | 7 |
| 2.3 | Rear Panel Identification and Connectors | 8 |
| 2.3.1 | Power Inlet | 8 |
| 2.3.2 | Antenna Input | 9 |
| 2.3.3 | Event Input | 9 |
| 2.3.4 | RS-232 and RS-485 Communication Ports | 10 |
| 2.3.5 | Form C, Relay Contacts | 10 |
| 2.3.6 | Standard Input/Outputs | 10 |
| 3 | Connecting Inlet Power, Input and Output Signals | 11 |
| 3.1 | Physical Configuration | 11 |
| 3.2 | Option 07, IEC-320 Power Inlet Module | 12 |
| 3.2.1 | Cordsets and Plug Styles for Option 07 | 12 |
| 3.2.2 | Option 07, Connecting Power to the 1084A/B/C | 12 |
| 3.3 | Option 08, 10 to 60 Vdc Power With Terminal Power Strip and Surge Withstand | 13 |
| 3.3.1 | Option 08, Connecting Inlet Power | 13 |
| 3.4 | Option 10, 110 to 370 Vdc Terminal Power Strip, Surge Withstand | 13 |
| 3.4.1 | Option 10, Connecting Inlet Power | 13 |
| 3.5 | Fuse Types and Locations | 14 |
| 3.5.1 | Replacing Fuses | 14 |
| 3.6 | Connecting Output Signals | 14 |
| 3.7 | Connecting Input Signals | 14 |

| | | |
|----------|---|-----------|
| 3.7.1 | Connecting an Event Input at P3 or Main RS-232 Port | 15 |
| 4 | GPS Antenna and Cable Information | 17 |
| 4.1 | GPS Antenna Installation | 17 |
| 4.1.1 | Mounting the Antenna | 17 |
| 4.1.2 | Optional Antenna Mounting Kit | 18 |
| 4.2 | Antenna and Cable Testing | 20 |
| 4.2.1 | Checking the Antenna Voltage | 20 |
| 4.2.2 | Power Supply Check | 20 |
| 4.2.3 | Checking the Antenna Resistance | 20 |
| 4.3 | Antenna Surge Suppressor | 20 |
| 4.3.1 | Using the Antenna Surge Suppressor | 20 |
| 4.4 | Technical Details on GPS, Antennas and Cables | 21 |
| 4.4.1 | Antenna Cable | 21 |
| 5 | Setting Internal Jumpers | 25 |
| 5.1 | Introduction | 25 |
| 5.2 | Output Function Selection | 25 |
| 5.2.1 | Output Function at P1, No Jumper | 26 |
| 5.3 | I/O Connector Used as Input, JMP1 | 26 |
| 5.3.1 | Event and Deviation Channel Configuration | 26 |
| 5.4 | Other Jumper Settings | 27 |
| 5.4.1 | Output Enable, JMP6 | 27 |
| 5.4.2 | Relay Control Output, JMP4 | 27 |
| 5.4.3 | Fiber Optic Output, JMP2 (Option 20) | 28 |
| 5.4.4 | Receiver Battery JMP5 (Option 02) – Obsolete | 28 |
| 6 | The Setup Menus | 29 |
| 6.1 | Setup Menus | 30 |
| 6.1.1 | To Begin Configuring | 30 |
| 6.1.2 | Numeric Data Entry Mode | 31 |
| 6.1.3 | Default Firmware Settings | 31 |
| 6.1.4 | To Exit Setup Menus | 31 |
| 6.2 | Setting the Main RS-232C Port | 32 |
| 6.2.1 | Setting Port Parameters | 33 |
| 6.2.2 | Setting the Broadcast Mode from Main RS-232 | 33 |
| 6.3 | Set Local Hour | 34 |
| 6.3.1 | Set Daylight Saving Time (DST) | 35 |
| 6.4 | Set Out of Lock | 36 |
| 6.5 | Set Back Light | 37 |
| 6.6 | Set System Delays | 38 |
| 6.7 | Set Programmable Pulse Mode | 39 |
| 6.7.1 | Entering Numerical Values | 39 |
| 6.7.2 | Prog Pulse – Seconds–Per–Pulse Mode | 40 |
| 6.7.3 | Prog Pulse – Pulse–Per–Hour Mode | 41 |
| 6.7.4 | Prog Pulse – Pulse–Per–Day Mode | 42 |
| 6.7.5 | Prog Pulse – Single Trigger | 43 |

| | | |
|----------|--|-----------|
| 6.7.6 | Prog Pulse – Slow Code | 44 |
| 6.7.7 | Prog Pulse – Pulse Polarity | 45 |
| 6.8 | Set IRIG Time Data | 46 |
| 6.9 | Setting the Event or Deviation Modes | 47 |
| 6.9.1 | Arming the Event Input | 47 |
| 6.10 | Setting the Auto Survey Mode | 48 |
| 6.10.1 | Number of Fixes | 48 |
| 6.11 | Set Position Hold ON or OFF | 49 |
| 6.12 | Set Option Control | 50 |
| 7 | Timing, IRIG-B and Pulses | 51 |
| 7.1 | Introduction | 51 |
| 7.2 | Timing Output Description | 52 |
| 7.2.1 | Standard Inputs/Outputs | 52 |
| 7.2.2 | Digital Drivers | 52 |
| 7.2.3 | Analog Driver | 52 |
| 7.3 | Output Signal Description | 53 |
| 7.3.1 | IRIG-B Description | 53 |
| 7.3.2 | Modulated and Unmodulated IRIG-B | 54 |
| 7.3.3 | Available IRIG-B Signals | 54 |
| 7.3.4 | IRIG-B IEEE 1344 Extension | 55 |
| 7.3.5 | 1 Pulse-per-Second (1 PPS) | 55 |
| 7.3.6 | Programmable Pulse (PROG PULSE) | 55 |
| 7.4 | Connecting Outputs | 55 |
| 7.4.1 | Attaching Cables to Screw Terminals | 56 |
| 7.4.2 | How Far Can I Run IRIG-B Cabling? | 56 |
| 7.4.3 | Synchronizing Multiple IED's From One Masterclock Output | 56 |
| 7.4.4 | Connecting Unmodulated IRIG-B | 57 |
| 7.4.5 | Connecting Modulated IRIG-B | 57 |
| 7.4.6 | Wire Losses | 57 |
| 7.4.7 | Voltage Matching for Modulated IRIG-B | 58 |
| 7.4.8 | Cable Delays | 58 |
| 7.4.9 | Solutions | 59 |
| 8 | Relay Contacts and Event Inputs | 61 |
| 8.1 | Relay Contacts, Out Of Lock and Fault | 61 |
| 8.1.1 | Introduction | 61 |
| 8.1.2 | Relay Operation | 61 |
| 8.2 | Event Inputs | 61 |
| 8.2.1 | Event Timing Input | 61 |
| 8.2.2 | Event Timing Latency | 62 |
| 8.2.3 | Deviation Measurement | 62 |
| 8.2.4 | Measurement Principle | 62 |
| 8.2.5 | Event Timer Input Channel Configuration | 62 |
| 8.2.6 | Firmware Setup | 62 |
| 8.2.7 | Displaying Data | 63 |

| | | |
|-----------|---|-----------|
| 8.2.8 | RS-232C Event Trapping | 64 |
| 8.2.9 | Event Trapping Setup | 64 |
| 9 | Serial Communication and Command Set | 65 |
| 9.1 | Introduction | 65 |
| 9.2 | Command Set | 65 |
| 9.2.1 | Broadcast Mode Commands | 67 |
| 9.2.2 | Event Mode Commands | 71 |
| 9.2.3 | Status Mode Commands | 73 |
| 9.2.4 | Local / Daylight Savings Time Setup Commands | 77 |
| 9.2.5 | Front Panel Control Commands | 78 |
| 9.2.6 | IRIG-B Data Output Commands | 79 |
| 9.2.7 | Position Data Commands | 80 |
| 9.2.8 | Survey Mode Commands | 82 |
| 9.2.9 | Date and Time Commands | 83 |
| 9.2.10 | Programmable Pulse Output Commands | 84 |
| 9.2.11 | Antenna System Delay Commands | 86 |
| 9.2.12 | Out-of-Lock Commands | 86 |
| 9.2.13 | Miscellaneous Commands | 86 |
| 9.3 | Communication Port Information | 88 |
| 10 | Startup and Basic Operation | 89 |
| 10.1 | Initial Startup Sequence | 89 |
| 10.1.1 | Clock Time, Startup Mode – 1084B/C | 89 |
| 10.2 | Front Panel Indication – 1084B/C | 90 |
| 10.2.1 | Display Indication at Startup | 90 |
| 10.2.2 | Other Display Indications When Unlocked | 90 |
| 10.2.3 | Status Display Indications | 91 |
| 10.2.4 | Event/Deviation Display | 91 |
| 10.2.5 | IRIG-B Time Data | 92 |
| 10.3 | Clock Status Display Mode | 92 |
| 10.4 | Time Display Modes – 1084B/C | 92 |
| 10.4.1 | Date and Time Display, Universal Time Coordinated (UTC) | 92 |
| 10.4.2 | Time of Year Display, UTC | 93 |
| 10.4.3 | Date and Time Display, Local Time | 93 |
| 10.4.4 | Time of Year Display, Local Time | 93 |
| 10.4.5 | Daylight Saving–Summer Time | 94 |
| 10.5 | Position Display Modes – 1084B/C | 94 |
| 10.5.1 | Longitude Display | 94 |
| 10.5.2 | Latitude Display | 94 |
| 10.5.3 | Elevation Display | 94 |
| A | Technical Specifications and Operating Parameters | 95 |
| A.1 | Scope | 95 |
| A.2 | Receiver Characteristics | 95 |
| A.2.1 | Input Signal | 95 |
| A.2.2 | Timing Accuracy | 95 |

| | | |
|----------|--|------------|
| A.2.3 | Internal Oscillator, Stability | 95 |
| A.2.4 | Allen Variance (locked to GPS, in Position–Hold Mode | 95 |
| A.2.5 | Position Accuracy (rms) | 96 |
| A.2.6 | Satellite Tracking | 96 |
| A.2.7 | Acquisition | 96 |
| A.3 | I/O Configuration | 96 |
| A.3.1 | I/O Connectors | 96 |
| A.3.2 | Standard Output Signals | 96 |
| A.3.3 | Relay Contacts | 97 |
| A.3.4 | Programmable Pulse Output | 97 |
| A.3.5 | Event A Input | 97 |
| A.4 | Antenna System | 97 |
| A.4.1 | Antenna Cable | 97 |
| A.5 | Operator Interface | 97 |
| A.5.1 | Setup Methods | 97 |
| A.5.2 | Setup Functions | 98 |
| A.5.3 | Display | 98 |
| A.5.4 | Display Functions | 98 |
| A.5.5 | Annunciators | 98 |
| A.6 | System Interface | 99 |
| A.6.1 | RS-232C Interface | 99 |
| A.6.2 | Data Formats | 99 |
| A.7 | Physical Specifications | 100 |
| A.7.1 | Dimensions | 100 |
| A.7.2 | Weight | 100 |
| A.7.3 | Power Requirements | 100 |
| A.7.4 | Power Connector | 100 |
| A.7.5 | Electro-Magnetic Interference (EMI) | 100 |
| A.7.6 | Temperature and Humidity | 101 |
| B | Using Surge Protectors | 103 |
| B.1 | Introduction | 103 |
| B.2 | Grounding | 103 |
| C | Options List | 105 |
| C.1 | Introduction | 105 |
| C.2 | Option 01: Backlighted LCD Display | 106 |
| C.2.1 | General Description – 1084B/C Only | 106 |
| C.2.2 | Specifications | 106 |
| C.2.3 | Configuration | 106 |
| C.3 | Option 02: GPS Battery Backup - <i>Obsolete</i> | 107 |
| C.3.1 | General Description | 107 |
| C.3.2 | Specifications | 107 |
| C.4 | Option 03: Four Additional Outputs | 108 |
| C.4.1 | General Description | 108 |
| C.4.2 | Specifications | 108 |

| | | |
|---------|---|-----|
| C.4.3 | Digital Outputs | 108 |
| C.5 | Option 04: ON/OFF Switch | 113 |
| C.6 | Option 06: Parallel BCD Output (1 millisecond Resolution) | 114 |
| C.6.1 | General Description | 114 |
| C.6.2 | Option 06 Firmware Setup | 115 |
| C.6.3 | Specifications | 116 |
| C.6.4 | Digital Outputs | 117 |
| C.6.5 | Option 06 Connector Pin Designation | 118 |
| C.6.6 | Configuration | 120 |
| C.7 | Option 07: Inlet Power Supply Description | 125 |
| C.7.1 | 85 to 264 Vac, 47 to 440 Hz, 110 to 370 Vdc, IEC-320 Connector | 125 |
| C.7.2 | Specifications | 125 |
| C.8 | Option 08: Inlet Power Supply Description | 126 |
| C.8.1 | 10 to 60 Vdc ONLY, Terminal Power Strip, SWC | 126 |
| C.8.2 | Specifications | 126 |
| C.9 | Option 10: Inlet Power Supply Description | 127 |
| C.9.1 | 110 to 370 Vdc, 85 to 264 Vac, 47 to 440 Hz Terminal Power Strip, SWC | 127 |
| C.9.2 | Specifications | 127 |
| C.10 | Option 17: Parallel BCD Output and Second RS-232C Port | 128 |
| C.10.1 | General Description | 128 |
| C.10.2 | Option 17 Firmware Setup Procedure | 129 |
| C.10.3 | Specifications | 130 |
| C.10.4 | Digital Outputs | 131 |
| C.10.5 | Option 17 Connector Pin Designation | 133 |
| C.10.6 | Configuration | 135 |
| C.11 | Option 19: Second RS-232C Interface | 140 |
| C.11.1 | General Description | 140 |
| C.11.2 | Specification | 140 |
| C.12 | Option 20A: Four Fiber Optic Outputs | 141 |
| C.13 | Option 23, COMTRADE Sample Rate Generator | 144 |
| C.13.1 | General Description | 144 |
| C.13.2 | Principles of Operation | 144 |
| C.13.3 | Other Features | 144 |
| C.13.4 | Specifications | 145 |
| C.13.5 | Performance | 146 |
| C.13.6 | Outputs | 146 |
| C.13.7 | Drive Capability | 146 |
| C.13.8 | Setup | 146 |
| C.13.9 | Option 23, Front Panel Setup | 147 |
| C.13.10 | Changing Hardware Settings via Internal Jumpers | 148 |
| C.14 | Option 27: 8-Channel High Drive | 151 |
| C.14.1 | General Description | 151 |
| C.14.2 | Specifications | 151 |
| C.14.3 | Option Setup | 151 |
| C.15 | Option 28: Power System Time, Frequency and Phase Monitor | 153 |
| C.15.1 | General Description | 153 |

| | |
|---|------------|
| C.15.2 Discussion | 153 |
| C.15.3 System Reference Connection | 153 |
| C.15.4 Firmware Configuration | 153 |
| C.15.5 Calibration | 155 |
| C.15.6 Phase Calibration | 155 |
| C.15.7 Amplitude Calibration | 155 |
| C.15.8 Option 28 Firmware Setup Procedure | 156 |
| C.15.9 Option 28-Specific RS-232 Commands | 157 |
| C.15.10 Option 28 Commands | 158 |
| C.16 Option 29: Four Additional Outputs; Dry Contacts; +25/50 Vdc | 163 |
| C.16.1 General Description | 163 |
| C.16.2 Specifications | 163 |
| C.16.3 Firmware Configuration | 165 |
| C.16.4 Output Jumper Setting Changes | 166 |
| C.17 Option 32: Internal NTP Server | 168 |
| C.17.1 General Description | 168 |
| C.17.2 Jumper Settings. | 170 |
| C.17.3 Firmware Configuration. | 171 |
| C.17.4 General Configuration | 173 |
| C.17.5 NTP Server Parameters | 174 |
| D CE Mark Certification | 175 |
| D.1 Introduction | 175 |
| E Statement of Compliance | 179 |
| E.1 Introduction | 179 |

List of Figures

| | | |
|------|--|----|
| 1.1 | Packaging of Accessories | 2 |
| 1.2 | Attaching Rack-Mount Ears | 3 |
| 2.1 | Model 1084A/B/C Front Panel Description | 6 |
| 2.2 | Model 1084A/B/C Rear Panel Description | 8 |
| 2.3 | Option 07 Power Supply Inlet Connector | 9 |
| 2.4 | Option 08 Power Supply Inlet Connector | 9 |
| 2.5 | Option 10 Power Supply Inlet Connector | 9 |
| 2.6 | GPS Antenna Connector | 9 |
| 2.7 | Communications Port Connector | 10 |
| 2.8 | Relay Contact Connectors | 10 |
| 2.9 | Standard Input/Output Connectors | 10 |
| 3.1 | Option 07 Power Supply Inlet Description | 12 |
| 3.2 | Option 08 Power Supply Inlet Description | 13 |
| 3.3 | Option 10 Power Supply Inlet Description | 13 |
| 4.1 | Antenna Assembly for Mounting | 18 |
| 4.2 | Antenna Mounting Bracket | 19 |
| 4.3 | Antenna Mounting with AS0044600 | 19 |
| 4.4 | GPS Surge Suppressor | 20 |
| 5.1 | Model 1084A/B/C Main Board | 26 |
| 6.1 | Main RS-232C Setup | 32 |
| 6.2 | Port Parameter Setup | 33 |
| 6.3 | Broadcast Setup | 33 |
| 6.4 | Local Hour Setup | 34 |
| 6.5 | Auto Daylight Saving Setup | 35 |
| 6.6 | Out-of-Lock Setup | 36 |
| 6.7 | Back Light Setup | 37 |
| 6.8 | System Delay Setup | 38 |
| 6.9 | Programmable Pulse Setup | 39 |
| 6.10 | Seconds-Per-Pulse Setup | 40 |
| 6.11 | Pulse-Per-Hour Setup | 41 |
| 6.12 | Pulse-Per-Day Setup | 42 |
| 6.13 | Single Trigger Setup | 43 |

| | | |
|------|---|-----|
| 6.14 | Slow Code Setup | 44 |
| 6.15 | Pulse Polarity Setup | 45 |
| 6.16 | IRIG-B Time Data Setup | 46 |
| 6.17 | Event/Deviation Mode Setup | 47 |
| 6.18 | Arming the Event Mode From Front Panel | 47 |
| 6.19 | Survey Mode Setup | 48 |
| 6.20 | Position Hold Mode Setup | 49 |
| 6.21 | Option Control Setup | 50 |
| 7.1 | Rear Panel Descriptions | 52 |
| 7.2 | IRIG-B Waveforms | 54 |
| C.1 | Option 03 Jumper Configuration | 111 |
| C.2 | Model 1084A/B/C Clocks | 113 |
| C.3 | Option 06 Firmware Setup | 115 |
| C.4 | Option 06 Output Connector | 119 |
| C.5 | Option 06 Output Jumper Settings | 123 |
| C.6 | Option 06 Board Layout and Jumper Locations | 124 |
| C.7 | Option 07 Power Supply Inlet Description | 125 |
| C.8 | Option 08 Power Supply Inlet Description | 126 |
| C.9 | Option 17 Firmware Setup | 129 |
| C.10 | Option 17 Output Connector | 134 |
| C.11 | Option 17 Output Jumper Settings | 138 |
| C.12 | Option 17 Board Layout and Jumper Locations | 139 |
| C.13 | Option 20A Jumper Locations | 143 |
| C.14 | Option 23 Front Panel Setup | 147 |
| C.15 | Option 23 Internal Jumper Setup | 150 |
| C.16 | Option 27 Jumper Locations | 152 |
| C.17 | Option 28 Firmware Setup Procedure | 156 |
| C.18 | Option 29 Jumper Locations | 166 |
| C.19 | Option 29 Connector – Signal Locations | 167 |
| C.20 | Option 32 Rear Panel | 169 |
| C.21 | Option 32 Board–Jumper Locations | 171 |

List of Tables

| | | |
|------|--|-----|
| 2.1 | Annunciator LED Definitions | 6 |
| 2.2 | Command Key Definitions | 7 |
| 3.1 | Available IEC-320 Cordsets by Country | 12 |
| 3.2 | Fuse Chart | 14 |
| 4.1 | Antenna Mounting Bracket Parts List | 18 |
| 4.2 | GPS Cable Data and Accessory Information | 22 |
| 5.1 | Output Signal Selection Jumper Settings | 25 |
| 5.2 | JMP1, Event Input Jumper Selection | 27 |
| 5.3 | Relay Output Control, JMP4 | 27 |
| 5.4 | Fiber Optic Output, JMP2 | 28 |
| 6.1 | Front-Panel Setup Menus | 30 |
| 6.2 | Default Firmware Settings | 31 |
| 7.1 | Drive Current vs. Voltage | 53 |
| 7.2 | IRIG-B Time Code Types Available | 53 |
| 7.3 | IRIG-B Code Designations | 54 |
| 7.4 | IRIG-B Code Designations | 56 |
| 9.1 | Fault Indications and Definitions | 68 |
| 9.2 | Survey (Sn) / Position-Hold Status (Pm) | 75 |
| 9.3 | System Status Information Chart | 76 |
| 9.4 | Unlocked Time Quality | 76 |
| 9.5 | Auto Survey Setup Conditions | 82 |
| 9.6 | Option Control Settings | 87 |
| 9.7 | Main RS-232C Port Pin Definitions | 88 |
| 10.1 | Fault Conditions | 92 |
| A.1 | Setup Functions Listed | 98 |
| A.2 | Main RS-232 Port Pin Definitions | 99 |
| A.3 | Temperature and Humidity List | 101 |
| C.1 | Output Connector Jumper Settings | 112 |
| C.2 | Option 06 Connector Pin Designation | 119 |

| | | |
|------|---|-----|
| C.3 | Option 17 Connector Pin Designation | 133 |
| C.4 | Option 19, Second RS-232 Port Pin Locations | 140 |
| C.5 | Option 20A, Four Fiber Optic Output Configuration | 142 |
| C.6 | Option 23, Sample Rates, $f_{LCM} = 384 \times f_{base}$ | 145 |
| C.7 | Option 23, Sample Rates, $f_{LCM} = 3200 \times f_{base}$ | 145 |
| C.8 | Option 23, Output Signal Selection Jumper Settings | 149 |
| C.9 | Option 28 B2 Broadcast, Time Deviation Values | 160 |
| C.10 | Operating Modes of SSR Outputs | 164 |
| C.11 | Output Connectors and Setup Jumpers | 165 |
| C.12 | JMP1 and JMP2 Settings | 170 |
| C.13 | JMP3 Settings | 170 |

Chapter 1

Unpacking the Clock

1.1 Introduction

This section will assist you with unpacking the clock from its shipping container; other parts and accessories shipped with the clock include:

- 1084A/B/C GPS Clock (includes internal power supply)
- Antenna Cable, 50 feet with connectors
- GPS Antenna
- Rack-Mount Ears, 2 ea.
- Instrument Manual
- Setup Guide

1.2 Precautions

Mechanical Shock Note that the GPS antenna is small and smooth, and can be damaged if dropped. Use care when handling. Remember to store the antenna in a safe place before the final installation.

Static Discharge Note that the Model 1084A/B/C series clocks are electronic devices and use static-sensitive components in their operation. Therefore, use care when handling against static discharges. Generally, these components are protected in their normal situation, however some of these are accessible when the cover is removed.

CAUTION Antenna Input Connector - Connect only the antenna cable coming from the antenna into this connector. The antenna input connector on the clock itself leads to the GPS receiver, which could be damaged from high voltage or a static discharge.

1.3 Unpacking and Locating Accessories

The Model 1084A/B/C series clocks, and included accessories, are packed between two closed-cell foam shells. Carefully pull apart the two shells to extract the clock and accessories. Some of the accessories (i.e. antenna and rack-mount ears) are located in one of these shells for protection. In the diagram below, you can see how the GPS antenna and rack-mount ears are located in the closed-cell foam marked with the label that reads,

ADDITIONAL PARTS INSIDE

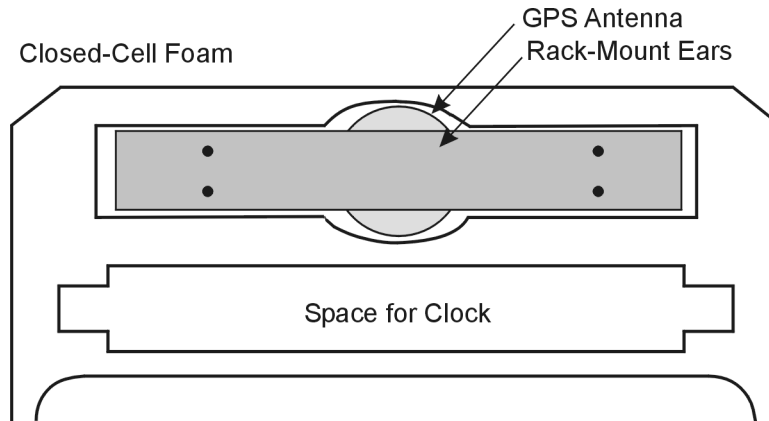

Figure 1.1: Packaging of Accessories

Antenna cable, clock and operation manual are located between the two pieces of closed-cell foam. *The rack-mount ears and antenna are embedded in the packing foam side labeled ADDITIONAL PARTS INSIDE.*

1.4 Attaching Rack-Mount Ears to 1084A/B/C Series Clocks

Each Model 1084A/B/C comes with two rack-mount ears suitable for mounting in a 19-inch system rack. These ears have four mounting holes, two of which are used to attach them to the sides of the clock. Since it is required to remove the M25 screws which attach the cover to the chassis, it may be good to attach the ears after first making any jumper configuration inside the clock. *You will want to return to this section after making these changes.*

1.4.1 Mounting Instructions

1. Using a Torx T25 driver or large slot screwdriver, remove the four M25 screws attaching the clock cover to the chassis. Use either a T-25 or large slot screwdriver.
2. With the ear facing out from the front panel, match the lower set of holes of the ear to the cover/chassis and remount the M25 screws.
3. Repeat this procedure with the other side of the chassis and other ear.

NOTE: Before installing the rack-mount ears, you might want to determine if you need to set any internal jumpers. To install the rack-mount ears requires removal of the top cover, which would be a good time to make any changes to jumper settings. See Chapter 5, Setting Internal Jumpers, for information on doing this.

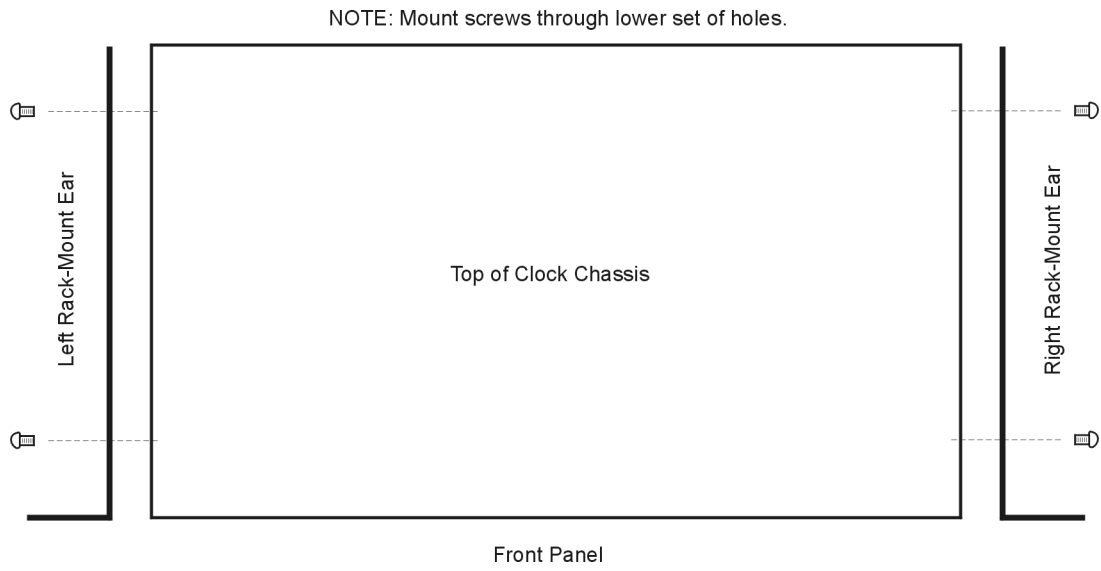

Figure 1.2: Attaching Rack-Mount Ears

Chapter 2

Front and Rear Panels

2.1 Introduction

This section identifies the connectors, controls, and displays found on the front and rear panels of the 1084A/B/C series clocks. Take care to review all of these items prior to connecting cables to and configuring these products.

2.2 Front Panel Controls and Indicators

The front panels of the Model 1084A/B/C series clocks are different from one another because of the arrangement of LED indicators, display(s) and keypad. See Figure 2.1 to see the difference between these models.

The Model 1084A has four annunciator LED's; the Model 1084B adds to that the two-line by twenty-character LCD and eight-button keypad; the Model 1084C adds to the Model 1084B another nine-character, LED for higher visibility. ON/OFF switch is optional and can be added for a small charge. The upper row of keys are Information keys and the lower row of keys are Configuration keys. In the figure below are illustrated the front panels of all of these clocks, illustrating all of the indicators and controls.

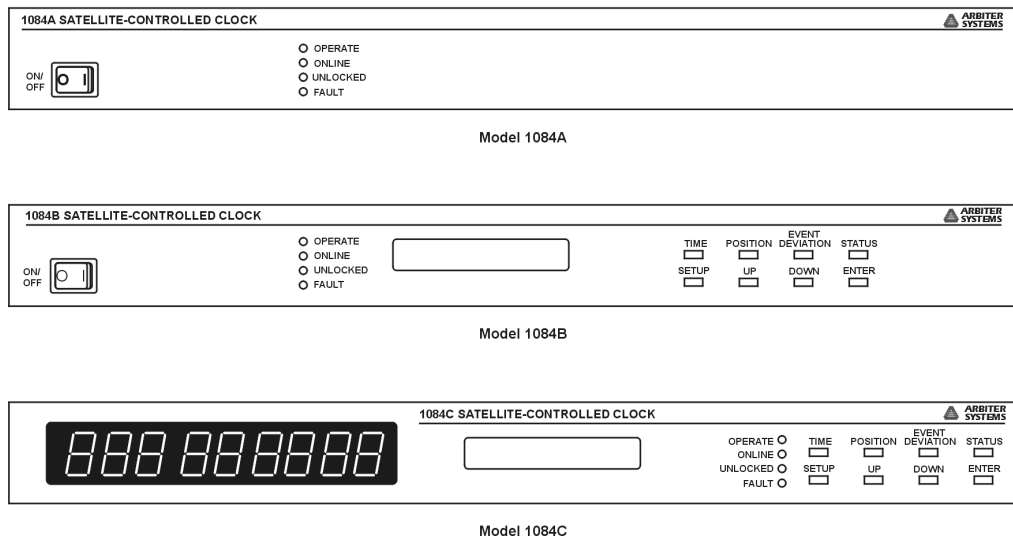

Figure 2.1: Model 1084A/B/C Front Panel Description

Definitions for the annunciator LEDs are found in Table 2.1 and definitions for keys in Table 2.2. Each of upper row of keys allow you to view clock information, like Time and Date, Geographical Position and Instrument Status. Each of the lower row of keys have specific and alternate functions for configuring operation. To configure, see Chapter 6, The Setup Menus.

2.2.1 Annunciator LED Definitions

| Annunciator LED | Color | Purpose |
|-----------------|-------|----------------------------|
| Operate | Green | Clock Operating |
| On Line | Green | Indicates Active Clock* |
| Unlocked | Red | Out-of-Lock when ON |
| Fault | Red | Internal/External Faults** |

Table 2.1: Annunciator LED Definitions

* When used with Option 18, Redundant Interface, the On Line LED indicates which of the two interconnected clocks is active.

** Illuminates when a fault condition exists with the clock or GPS receiver.

2.2.2 Command Key Definitions

Table 2.2 subdivides all of the functions of the eight keys by name and function. Some of the keys have alternate functions as well.

| Key | Function | Alternate Function |
|--------------------|--|--------------------------------------|
| TIME | time and date | NA |
| POSITION | view latitude, longitude and elevation | NA |
| EVENT or DEVIATION | view event or deviation | NA |
| STATUS | view clock and receiver status | NA |
| SETUP | enter setup mode | move cursor left in data entry mode |
| UP | select upper value | increase numerical value |
| DOWN | select lower value | decrease numerical value |
| ENTER | install selected value | move cursor right in data entry mode |

Table 2.2: Command Key Definitions

2.2.3 LED Status Indicators

Four LED's provide information about the operational status of the instrument. The Operate and On Line LEDs are green and the Out-of-Lock and Fault LEDs are red. For normal operation, with the clock locked and accurate, the two green LEDs should be ON and the two red LEDs should be OFF. The following definitions apply to these indicators:

- **OPERATE:** Indicates that power is being supplied to the clock.
- **ON LINE:** Indicates the active clock, especially when using the Option 18, Redundant Interface, when two clocks are interconnected.
- **OUT OF LOCK:** Illuminates when the clock has not yet synchronized, or has lost synchronization, with the GPS.
- **FAULT:** Indicates when a GPS receiver or clock fault occurs.

2.2.4 LCD Display

The Model 1084B and 1084C series clocks contain a liquid crystal display (LCD), which provides a 20-character by 2-line readout. The readout displays instrument status, time, position and event/deviation data. The readout is also used to display the current configuration of operation parameters.

2.2.5 Front Panel Keys

Control various functions and configuration of operational parameters using the eight pushbutton keys on the front panel. However, using an RS-232 command, you can control the operation of the keypad and display (lock, enable, blank). Refer to Section 9.2.5, in the Serial Communication

and Command Set, for a detailed description of RS-232 commands to control the front panel. The front-panel pushbutton keys are described below.

Time

Sets the display to the Time Display Mode. There are four modes of the time display available and repeated pressing of this key will cause the display to scroll through all four modes. Changing the time display has no effect on the time data, which is output from rear-panel timing outputs.

Position Cycles the display through the longitude, latitude, and elevation data readouts of the antenna location according to the most recent, or averaged, position fix.

Event/Deviation Selects Event and/or Deviation Data recorded by the specific Model clock; up to 500 event records or updated 1-PPS deviation data. For additional details, see Event Inputs in Chapters 5, 6, 8 and 9.

Status Toggles the display between four status display modes: Clock, Receiver, DXCO and EEPROM, including the display of GPS satellite acquisition and synchronization.

Setup Invokes a series of menus used to adjust configurable parameters within the clock. In numeric data entry mode, moves the cursor to the left.

Up Used in conjunction with the Setup menus to adjust values upward, or to scroll upward through the available menu choices. Also assists in navigating through main Setup menus in normal order.

Down Used in conjunction with the Setup menus to adjust values downward, or to scroll downward through available menu choices. Also assists in navigating through main Setup menus in reverse.

Enter Used for confirming changes made within Setup menus. Generally, pressing Enter also advances to the next parameter, or returns to the previous menu level. In numeric data entry mode, moves the cursor to the right.

2.3 Rear Panel Identification and Connectors

This section contains information to assist you in identifying where to connect inlet power, the GPS antenna cable and all of the input and output cables on the Model 1084A/B/C series clocks.

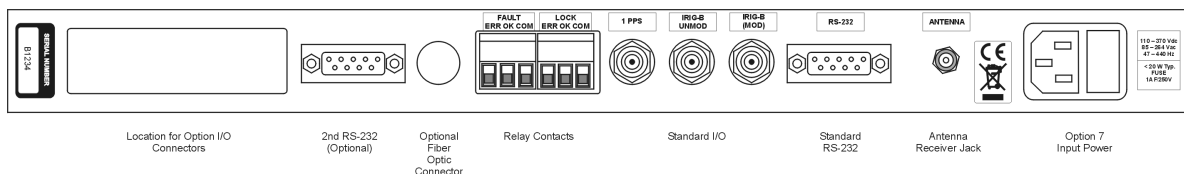

Figure 2.2: Model 1084A/B/C Rear Panel Description

2.3.1 Power Inlet

To cover all of the possible inlet power conditions, the Model 1084A/B/C has three optional power supplies. Please examine the paperwork you received, to make sure you have correctly identified the inlet connection. Supply types are listed below:

- Option 07, IEC-320 supply with a range of 86 to 264 Vac, 47 to 440 Hz and 110 to 370 Vdc

Figure 2.3: Option 07 Power Supply Inlet Connector

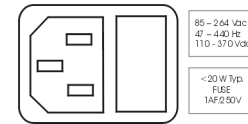

- Option 08, 10 to 60 Vdc ONLY, Terminal Power Strip with Surge Withstand Protect Circuitry (SWC) power

Figure 2.4: Option 08 Power Supply Inlet Connector

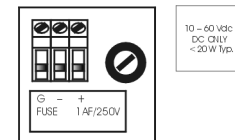

- Option 10, 110 to 370 Vdc and 85 to 264 Vac, 47 to 440 Hz, Terminal Power Strip with Surge Withstand Protect Circuitry (SWC)

Figure 2.5: Option 10 Power Supply Inlet Connector

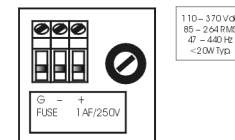

2.3.2 Antenna Input

The Model 1084A/B/C provides a type-F, GPS antenna input connector not only as the connection point for GPS signal, but also supplies 5 volts to energize the antenna. It is equipped with a threaded, type-F female connector.

Shown below is a diagram of the antenna connector. To check for this signal, use a small multimeter and probe from the center pin of the connector to the threads. Voltage range is 4.9 to 5.1 Vdc. For further information, see Chapter 4, Antenna and Cable Information.

Figure 2.6: GPS Antenna Connector

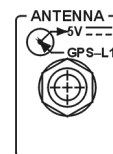

2.3.3 Event Input

For timing external events based on the GPS-synchronized time, use the Event Input function with two separate connectors: P3 (Standard I/O) and J2 (RS-232C). See Figure 5.1, which illustrates the location of these connectors and jumpers.

2.3.4 RS-232 and RS-485 Communication Ports

The Model 1084A/B/C have one standard and one optional communication ports with RS-232 and RS-485 supported. The RS-232 port does not use flow control and the RS-485 is transmit only (uses Transmit A and Transmit B, no Receive A and Receive B). Generally, for RS-232 communications, you will only need pins 2, 3 and 5 using a null-modem cable. For more information, see Chapter 9, Serial Communications and Command Set.

RS-232C



Figure 2.7: Communications Port Connector

2.3.5 Form C, Relay Contacts

The Model 1084A/B/C has two sets of Form C relay contacts that have three contact points: Normally Open (NO), Normally Closed (NC) and Common (C). For information on how to connect to them and their specifications, see Chapter 8, Relay Contacts and Event Inputs.

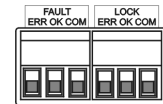

Figure 2.8: Relay Contact Connectors

2.3.6 Standard Input/Outputs

The Model 1084A/B/C has three timing output connectors for separate timing signals: unmodulated IRIG-B, modulated IRIG-B and 1 Pulse Per Second (PPS). Viewed from the rear panel, they are labeled IRIG-B UNMOD, IRIG-B MOD (Option 92), 1 PPS from left to right. Single connectors may also be "Tee'ed" for parallel-connected loads. For more information concerning how to connect any timing output in parallel, for distribution, see Chapter 7, Timing, IRIG-B and Pulses.

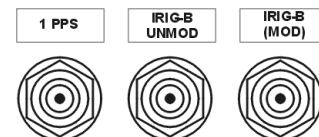

Figure 2.9: Standard Input/Output Connectors

Chapter 3

Connecting Inlet Power, Input and Output Signals

3.1 Physical Configuration

The Model 1084A/B/C Satellite-Controlled Clock is designed for operation in an environment having an ambient temperature range of 0° to 50° C (32° to 122° F). No external ventilation is necessary. Operation is possible at temperatures of -20° to +65° C, although operation of the LCD display will be degraded (Model 1084A is not affected). Normal operation will be restored once the temperature has returned to the specified range.

Allow adequate clearance for rear-panel connections, especially in rack-mounting situations. Adequate clearance reduces the possibility of damage to the connectors, cables, or the instrument. Ideally, the clock should be located close enough to the antenna location so that the standard 15-meter (50-foot) cable can be used. The loss and delay characteristics of the cable are important factors in the calibration and accuracy of the instrument (refer to Section 4.4.1); thus, the entire cable length should be used, with any excess coiled up and placed out of the way.

Arbiter Systems offers standard accessories allowing the antenna to be mounted up to 240 m (800 ft) from the clock if longer cable runs are required. These are described in Table 4.2. If a longer antenna cable than this is required, please contact the factory for advice.

Model 1084A/B/C Power Supplies

To provide for a wide range of inlet power sources, the 1084A/B/C can be ordered with three different power inlet modules. Each of the power inlet module connectors are illustrated here and also in Chapter 2. Take time to examine the power inlet module connection on your clock to verify that it is correct according to your order. Make sure to check the inlet module before connecting power to the clock.

3.2 Option 07, IEC-320 Power Inlet Module

The Option 07, IEC-320 power inlet module has a “computer type” power connector with power cord for the required country code. Voltage and system frequency are given below with an outline of the connector. Input voltages are 85 to 264 Vac, 47 to 440 Hz, or 110 to 370 Vdc, < 20 Watts.

Figure 3.1: Option 07 Power Supply Inlet Description

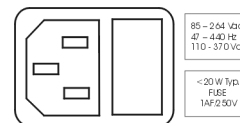

3.2.1 Cordsets and Plug Styles for Option 07

Make sure that the cordset matches the wall connector for your country. The following are available IEC-320 mating cordset plug style and specifications:

| No. | Country | Specification | Rating |
|-----|-----------------------|-------------------------|--------|
| P01 | Continental Europe | CEE 7/7 | 220V |
| P02 | Australia, NZ, PRC | AS3112-1981 | 240V |
| P03 | U.K. | BS 1363 | 240V |
| P04 | Denmark | Afsnit 107-2-01 | 240V |
| P05 | India | BS 546 | 220V |
| P06 | Israel | SI 32 | 220V |
| P07 | Italy | CEI 23-16/VII 1971 | 220V |
| P08 | Switzerland | SEV 1011.1959 | 220V |
| P09 | North America and ROC | NEMA 5-15P CSA C22.2#42 | 120V |
| P10 | Japan | JIS8303 | 120V |

Table 3.1: Available IEC-320 Cordsets by Country

3.2.2 Option 07, Connecting Power to the 1084A/B/C

Connect the IEC-320 plug to the IEC-320 connector on the 1084A/B/C, and then connect the wall plug into the wall socket.

3.3 Option 08, 10 to 60 Vdc Power With Terminal Power Strip and Surge Withstand

This option replaces the standard power supply with one accepting 10 to 60 Vdc (only), < 20 VA typical. Replaces the standard IEC-320 inlet with a 3-pole terminal strip. Provides input surge protection (SWC) for compliance with ANSI C37.90-1 and IEC 801-4. Option 08 operates from common low-voltage battery systems, including 12, 24, and 48 Vdc.

Figure 3.2: Option 08 Power Supply Inlet Description

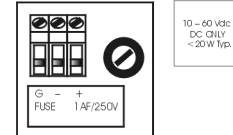

3.3.1 Option 08, Connecting Inlet Power

When wiring station batteries to this power supply, make sure to first connect an earth ground wire to the terminal strip connector labeled "G" (for ground). Line and neutral terminals are marked on a label below as "+" and "-". After connecting a ground wire, connect the positive and negative leads from the station batteries to the corresponding Option 08 terminals. Be sure to observe the correct polarity, as the power supply used with the Option 08 will not accept reverse input polarity. *CAUTION: DO NOT connect Option 08 module to any ac voltage source.*

3.4 Option 10, 110 to 370 Vdc Terminal Power Strip, Surge Withstand

This option replaces the standard IEC-320 inlet with a 3-pole terminal strip and provides input surge protection for compliance with ANSI C37.90-1 and IEC 801-4. Input voltages are: 85 to 264 Vac, 47 to 440 Hz, or 110 to 370 Vdc, < 20 VA typical.

Figure 3.3: Option 10 Power Supply Inlet Description

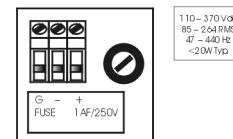

3.4.1 Option 10, Connecting Inlet Power

When wiring this power supply, make sure to first connect an earth ground wire to the terminal strip connector labeled "G" (for ground). Positive and negative terminals are marked on the terminals as "+" and "-." After connecting a ground wire, connect the positive and negative leads from the station batteries to the corresponding Option 10 terminals.

3.5 Fuse Types and Locations

Use the fusing table below for identifying the correct fuse for your option power supply.

| PS Option | Arbiter PN | Fuse ID | Size, mm |
|-----------|------------|----------|----------|
| 07 | FU0001816 | F1AL250V | 5 x 20 |
| 08 | FU0001416 | T1AL250V | 5 x 20 |
| 10 | FU0001816 | F1AL250V | 5 x 20 |

Table 3.2: Fuse Chart

3.5.1 Replacing Fuses

An IEC-320 power inlet connector includes a 1-A, 250-V fast acting fuse. The fuse is contained in a small compartment with a snap-fit latch, which also has a compartment for a spare fuse. Check Table 3.2 for replacement fuse information.

The fuse compartment is located directly adjacent to the input connector socket, and can be opened by pulling both sides directly out away from the chassis, or by gently prying with a small flag-blade screwdriver. To replace the fuse, first disconnect the line cord from the power source and then remove the cord from the rear-panel IEC connector. The in-circuit fuse is the innermost one; inspect it to determine if it is open. As required, replace with fuse in the outer compartment, and replace the spent fuse.

With an Option 08 or 10, the input power module includes separate fuse holder adjacent to the terminal power strip. See Table 3.2 above for the correct fuse configured for your option.

Option 08 and 10 fuses are located in a separate threaded compartment. To check the fuse, use a small flat-bladed screwdriver and turn the cover counter-clockwise. The cover and fuse should pop out. CAUTION: Replace fuse only with another of the same type and rating. See Table 3.2 above for the correct fuse configured for your option.

To replace the fuse, first disconnect inlet power from the clock. Using a small flat-blade screwdriver, turn the fuse cover counter-clockwise (CCW) and it should pop outward. Replace fuse with the same size and type.

3.6 Connecting Output Signals

Output signals may be connected through designated standard BNC or option connector. For standard I/O connectors, see Section 2.3.6. Connectors are standard female BNC. For Options that have terminals for output connectors, see Appendix C for details about those options and connectors. BNC connectors (on installed option boards) are female and require only connecting the (male) connector into it.

3.7 Connecting Input Signals

Input signals may be connected through the designated I/O terminals, the RS-232 connector and through an installed option connector designated as Input. For standard I/O connectors, see

Section 2.3.6. As an example, the Option 27 uses Phoenix-style terminals with 5-mm spacing and will accept between 0.25 and 2.5-mm wire diameter. For Options that have terminals for output connectors, see Appendix C for details about those options and connectors. BNC connectors (on installed option boards) are female and require only connecting the (male) connector into it.

3.7.1 Connecting an Event Input at P3 or Main RS-232 Port

An event input may be connected to the Model 1084A/B/C series clock through the P3 (the standard 1-PPS output) or the main RS-232C port. For complete details, see Section 5.3.1.

Before connecting any input signal to P3, make sure to read about how to wire P3 for input and configure it through the Event/Deviation menu (on 1084B/C models) or through the main RS-232 port (all models); see Section 5.3.1. To connect input wiring to P3, use either a shielded coax, or a pair of wires that are connected to a BNC male connector¹.

¹Alternately, use a BNC Breakout such as sold by Pomona Electronics, P/N 4970. www.pomonaelectronics.com, (888) 403-3360

Chapter 4

GPS Antenna and Cable Information

The Model 1084A/B/C come complete with the necessary hardware to be able to receive GPS signals: 50-feet of RG-6 cable and a GPS antenna. The antenna cable is connected between the female F connector on the antenna and the female F connector at the rear panel of the clock.

This section should help you with installing the GPS antenna and antenna cable(s) to the Model 1084A/B/C series clocks. It should also be a source of information if you should need to trouble shoot the antenna cable system. These clocks achieve their accuracy by comparing and adjusting the internal clock signal to the incoming GPS signal.

4.1 GPS Antenna Installation

To properly receive GPS signals, the GPS antenna needs to be mounted clear of buildings and surrounding elements that would block the GPS signals being transmitted by the satellites. For complete coverage, the antenna needs to have a clear view of the sky from 10 degrees above the horizon to directly overhead for all points of the compass. Minimal installations, where the antenna is mounted in a less favorable location, may work however reception may be somewhat limited during certain hours of the day.

4.1.1 Mounting the Antenna

To mount the antenna, you will need a short piece of gray, 3/4" plastic pipe nipple that can be attached to a solid fixture. The piece of pipe nipple should be threaded up into the antenna receptacle after connecting the antenna cable to the Type F cable adapter. Arbiter Systems sells an antenna mounting kit (P/N AS0044600) that simplifies installation, and is illustrated in Figures 4.1, 4.2 and 4.3.

Antenna mounting procedure:

1. Thread the RG-6 antenna cable through the plastic pipe
2. Tighten the Type F male connector to the antenna connector
3. Thread the plastic pipe into the antenna
4. Mount the plastic pipe and antenna/cable assembly to a fixture

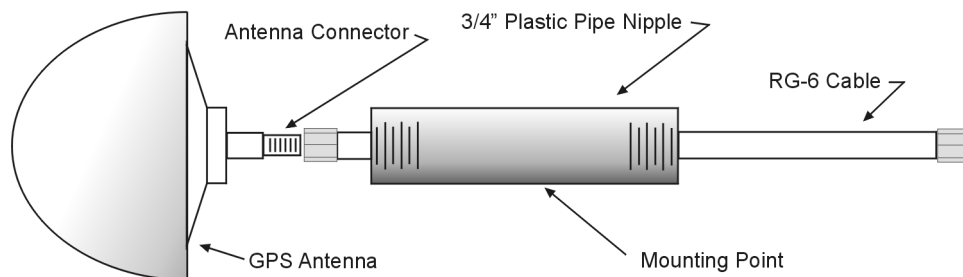

Figure 4.1: Antenna Assembly for Mounting

4.1.2 Optional Antenna Mounting Kit

The AS0044600 Antenna Mounting Kit (P/N AS0044600) is designed specifically for use with antennas shipped with Arbiter Systems GPS-controlled clocks. The hardware included with the bracket allows installation of the antenna on a mast or pipe up to about 2" in diameter, and a different clamp may be substituted for use with a larger diameter pipe. Also, the bracket can be mounted to a wall, a roof, or any other flat surface.

For complete details on this product request Installation Instructions for Arbiter Systems GPS Antenna Mounting Bracket on document number PD0024700A. All metallic hardware is stainless steel.

| Qty | Description | ASI P/N |
|-----|---|-----------|
| 1 | GPS antenna mounting bracket | HD0052700 |
| 1 | U-bolt, 1-1/8", with 2 hex nuts | HP0014700 |
| 1 | 3/4" x 4" threaded pipe, PVC, schedule 80 | HP0014800 |
| 1 | Hose clamp, worm drive | HP0014900 |
| 1 | Mounting bracket stabilizer | HD0054200 |

Table 4.1: Antenna Mounting Bracket Parts List

Figure 4.2 and 4.3 on page 19 illustrate the antenna mounting bracket and a typical installation using the AS0044600 Antenna Mounting Kit.

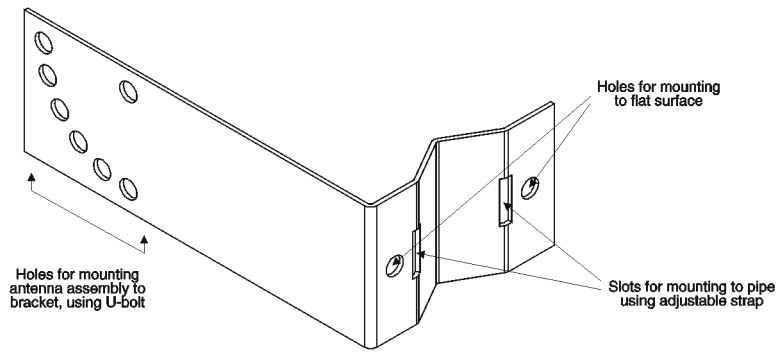

Figure 4.2: Antenna Mounting Bracket

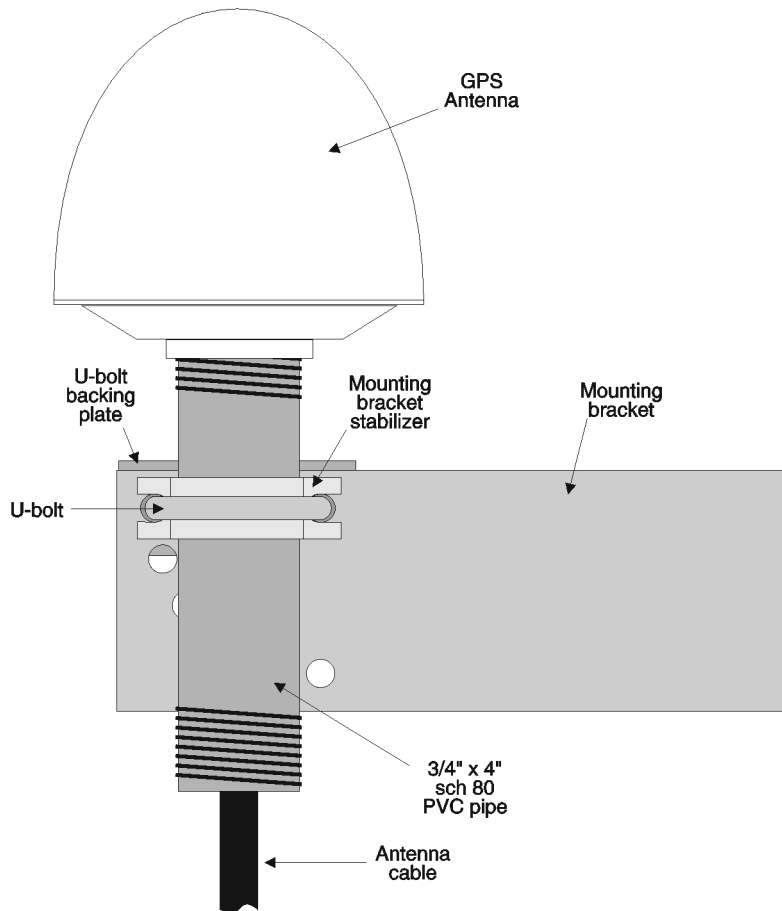

Figure 4.3: Antenna Mounting with AS0044600

4.2 Antenna and Cable Testing

The antenna and cable assembly can easily be tested prior to or after installation. All that is required is a basic multimeter that measures DC volts and resistance.

4.2.1 Checking the Antenna Voltage

The GPS clock provides a +5 Vdc signal at 30 mA maximum, carried through the antenna cable to the GPS antenna. Without the signal, the antenna and the GPS clock will not synchronize with the Global Positioning System and can generate an out-of-lock alarm, if the Out-of-Lock feature is enabled. You can verify this signal by setting your voltmeter to DC volts and measuring from the center pin to the threads at the antenna connector on the rear panel. This signal should be between 4.9 and 5.1 Vdc.

4.2.2 Power Supply Check

The Antenna Voltage test (above) actually tests the main power supply voltage for all models of clocks.

4.2.3 Checking the Antenna Resistance

The current antenna is a Trimble Bullet 3 and has a nominal internal resistance of about 270 ohms. Measure this with the antenna cable disconnected from the clock and connected to the antenna. This way you will know if you have a good connection. Change your multimeter to read resistance and measure from the center pin of the cable connector to the threads (shield).

4.3 Antenna Surge Suppressor

If you have ordered the GPS Surge Suppressor kit, you should mount it in line with the antenna cable. Additional information on grounding GPS antennas, and grounding in general, are available from Arbiter (Kit P/N AS0049000).

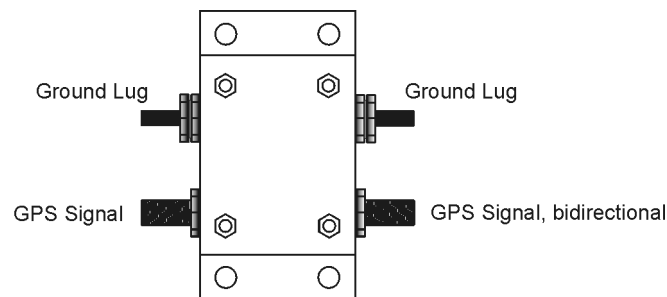

Figure 4.4: GPS Surge Suppressor

4.3.1 Using the Antenna Surge Suppressor

If using the antenna surge suppressor, it would be good to review documentation on this device, including tips on grounding. Please check Appendix B in this manual for details on the importance

of using surge suppressors and proper grounding.

4.4 Technical Details on GPS, Antennas and Cables

4.4.1 Antenna Cable

Length and Loss Considerations

Standard Antenna Cable

The standard antenna cable assembly included with the clock is constructed using a 15-meter (50-foot) length of RG-6 type low-loss coaxial cable, terminated with male Type F connectors. Optional lengths of RG-6 coax are separately available for longer runs; see Table 4.2, Cable Data and Accessory Information.

Effects of Cable Parameters

To receive GPS signals and properly operate the clock, the type and length of the cable are important. Due to their effect on specific parameters described in the following paragraphs, any changes to the length and/or type of antenna cable should be made carefully. Damaged cables may also affect performance.

Cable Delay

The velocity factor and the physical length of the cable determine cable delay. During the initial factory calibration of the clock, a value for cable delay (based upon the length and type of cable supplied) is entered into the clock memory. Firmware uses this figure to counteract the effect that the delay has upon GPS timing accuracy. The value entered for a standard 15-meter cable is 60 nanoseconds. For other cable options, the delay is tabulated below. The formula for calculating cable delay is:

$$(4.1) \quad T = \lambda \frac{1}{CKv} + 1ns$$

Where:

- T = Cable delay, in nanoseconds;
- λ = Cable length, in meters;
- C = Speed of light (3×10^8 meters per second);
- Kv = Nominal velocity of propagation (0.85).

One nanosecond is added to the calculated value to account for the length and velocity factor of the short connecting cable inside of the clock.

Attenuation

Attenuation depends upon the cable length, and the loss per unit length. The total attenuation must be limited to 21 dB (maximum) at the GPS L1 frequency of 1575.42 MHz. Loss up to 42 dB can be accommodated with the separately available 21-dB in-line preamplifier (P/N AS0044700).

DC Resistance

The cross-sectional area and length of the conductors in the cable determine the dc resistance. Since power to the RF preamplifier in the antenna is supplied via the antenna cable, excessive dc resistance will degrade performance.

Because of the above factors, changes to the length and/or type of antenna cable should be made carefully. Damaged cables may also affect performance.

Available Antenna Cables and Accessories for Longer Runs

Arbiter Systems offers longer antenna cables for use with all models of clocks when the standard 15-meter (50-foot) cable is inadequate. For RG-6 cable runs greater than 250 feet, up to 500 feet, Arbiter offers a 21-dB in-line amplifier, P/N AS0044700. A larger RG-11 style cable is available (P/N WC0004900, 305-m / 1000-ft roll), that can be used for runs to 120 meters (400 feet) without the in-line preamplifier, or 240 meters (800 feet) with the AS0044700 amplifier. See a list of these accessories in Table 4.2.

| P/N | Description | Delay, ns | Signal Level, dB |
|-----------|------------------------------------|-----------|------------------|
| CA0021315 | 15-m (50-ft) cable, RG-6 | 60 ns | -5 dB |
| CA0021330 | 30-m (100-ft) cable, RG-6 | 119 ns | -9 dB |
| CA0021345 | 45-m (150-ft) cable, RG-6 | 177 ns | -13 dB |
| CA0021360 | 60-m (200-ft) cable, RG-6 | 236 ns | -17 dB |
| CA0021375 | 75-m (250-ft) cable, RG-6 | 295 ns | -21 dB |
| WC0004900 | 305-m (1000-ft) roll RG-11 | 3.92 ns/m | -17.5 dB/100 m |
| AS0044800 | RG-11 crimp tool and 25 connectors | N/A | N/A |
| AS0044700 | 21-dB in-line amplifier | 1 ns | +21 dB |

Table 4.2: GPS Cable Data and Accessory Information

Physical Protection

When routing the antenna cable, protect it from physical damage, which may result from closing doors, falling objects, foot traffic, etc. Also, when routing around corners, allow for sufficient bend radius to prevent kinks. Extra length should be allowed at both ends of the cable to prevent tension on the connectors, which could cause damage or failure. Extra length is useful as a service loop, in the event that a connector needs replacement.

Do not stretch the cable mid-air over any appreciable distance without support. Cable degradation or failure could result. Always leave a drip loop wherever the cable enters a structure, to prevent water from entering the structure via the cable jacket. The maximum temperature rating for the type of cable provided with the clock is 60°C (140°F). Exercise care when routing the cable near sources of heat to avoid cable damage.

Adjacent Signals

Although the standard RG-6 style cable is triple-shielded and has excellent shielding properties, be cautious when routing near high power RF sources or alongside cables carrying high power RF, such as transmitter cables. In these applications, consider using RG-11 style cable (P/N WC0004900). Its quad-shielded design provides even more isolation.

Antenna Power

The RF preamplifier within the antenna requires 5 Vdc at 30 mA maximum for operation. A power supply within the clock generates this voltage, which is applied to the antenna via the two conductors of the coaxial antenna cable. Avoid shorting the center conductor to the shield of the coaxial cable as it may damage the preamplifier. Conversely, a high-resistance connection or open circuit would deprive the preamplifier of power. Either a short- or open-circuit condition in the antenna cable will render the clock inoperable.

Prior to initial operation or if problems are suspected, perform the Antenna/Cable Operational Test Procedure described in Section 4.2.

Connection to Antenna

The male Type F connector on one end of the antenna cable mates with the female Type F connector on the antenna. Avoid placing mechanical stress on the cable attachment to the antenna.

Connection to Clock

The male Type F connector on the opposite end of the antenna cable connects to the female Type F connector on the rear panel of the Substation Clock.

User-Supplied Antenna Cables

Any RF cable meeting the requirements described above for loss (< 21 dB at 1575 MHz) and dc resistance (< 15 ohms total loop resistance) may be used with the clock. However, prior to using a non-standard antenna cable, verify proper installation by performing the Power Supply Test and Antenna Resistance Test above.

For additional technical details concerning the GPS, GPS antennas and antenna cabling see Appendix A, Technical Details and Specifications.

Chapter 5

Setting Internal Jumpers

5.1 Introduction

Jumpers in the the 1084A/B/C series clocks are already set up at the factory according to the purchase order. If it should be necessary to change any jumpers or to enable any new function, you should follow the instructions in this section.

This section should assist you with understanding and setting the internal main board jumpers in these clocks. After correctly setting the necessary jumpers, go to Chapter 6, The Setup Menu, for details on how to configure these signals from the front panel keys. If your clock does not have a keypad and liquid crystal display (LCD) you will need to make configuration changes through the RS-232 port. If you wish to know additional technical details about timing signals, please see Chapter 7, Timing, IRIG-B, and Pulses. **NOTE:** *Values in tables marked with an “*” show default positions.*

5.2 Output Function Selection

Jumpers JMP3 and JMP2 determine which output signals are available at I/O connector P3 and the fiber-optic output connector U46 (Option 20) respectively. The position of the jumper determines which output signal will be made available at the specified I/O connector. Table 5.1 provides a cross-reference list of I/O connector, output signals, and jumper positions.

| Output Signal | P1, Fixed | P2, JMP9 [†] | P3, JMP3 | U46, JMP2* |
|--------------------|-----------|-----------------------|----------|------------|
| IRIG-B Manchester | N/A | N/A | B | B |
| 1 PPS | N/A | N/A | C* | C |
| IRIG-B Unmodulated | N/A | A* | A | A |
| Programmable Pulse | N/A | B | N/A | N/A |
| IRIG-B Modulated | Yes | N/A | N/A | N/A |

Table 5.1: Output Signal Selection Jumper Settings

*Default positions; U46 (JMP2) determined when Option 20 is ordered.

[†]Not available on early versions.

Model 1084A/B/C there are two I/O connectors, which can also be used for an input function. These input functions and their assigned connectors are as follows:

| I/O Connector | Function | Jumper No. & Position |
|---------------|-----------------------|-----------------------|
| J2 | RS-232 | JMP 1, Position "A" |
| P3 | Channel A Event/1 PPS | JMP 1, Position "B"* |

Table 5.2: JMP1, Event Input Jumper Selection

Wiring for Channel A Event/1 PPS Usage

To use P3 as a data line to trigger the event timer, first remove R44 (see Figure 5.1) and add a wire on the main board from the left-hand side (facing front of instrument) of where R44 was located to JMP1, position B. Then set JMP1 to position B. It is not necessary to perform this modification when using the main RS-232 port as an event input. Just set JMP1 to position A.

5.4 Other Jumper Settings

5.4.1 Output Enable, JMP6

The factory uses jumper JMP6 for enabling the 5 V CMOS output buffers. For normal operation, set jumper to position A. Normally, this jumper will be configured as required when delivered from the factory. **Note:** JMP6 is located near Pin-40 of U1; however, its reference designation was inadvertently omitted from the silk screen on some early units.

5.4.2 Relay Control Output, JMP4

Jumper JMP4 is used to control, which relay contact function is available at rear panel connector J3: 1 PPH, Programmable Pulse, or Fault (Fail-Safe). Output signals and jumper positions are as follows:

| Relay Output Signal | JMP4 Position |
|---------------------|---------------|
| 1 PPH | A |
| Programmable Pulse | B |
| Fault (Fail-Safe)* | C |

Table 5.3: Relay Output Control, JMP4

*Default

5.4.3 Fiber Optic Output, JMP2 (Option 20)

Jumper JMP2 is used to control which output signal is available at the Fiber Optic rear panel connector U46: IRIG-B Unmodulated, IRIG-B Modified Manchester, or 1 PPS. Output signals and jumper positions are as follows:

| Output Signal | JMP2 Position |
|----------------------------|---------------|
| IRIG-B Unmodulated | A |
| IRIG-B Modified Manchester | B |
| 1 PPS | C |

Table 5.4: Fiber Optic Output, JMP2

5.4.4 Receiver Battery JMP5 (Option 02) – Obsolete

Not used on current Model 1084A/B/C clocks. Earlier clocks, with Option 02, use a circuit board mounted Ni-Cd battery enabled with JMP5. New Model 1084A/B/C clocks use a receiver with its own manganese dioxide rechargeable lithium ($\text{MnO}_2 - \text{Li}$) data backup battery. These batteries offer approximately 1 month of battery backup service with loss of instrument power. Backup batteries are kept charged under normal conditions from the clock power supply and have an expected life of 5 years or more.

Chapter 6

The Setup Menus

This section should guide you in configuring the Model 1084A/B/C operation using the SETUP Menus or RS-232C port(s). These menus allow you to configure the operation according to your preferences. Logically, use the setup menus after installing the clock for the first time, or changing any of the main board jumpers as described in Chapter 5.

Two of the most common setup menus for any application are (1) configuring the Local Offset and Daylight Saving values, and (2) setting up the IRIG-B outputs for the correct time zone. To operate with the correct time in your location, you will need to configure the Local Offset (from UTC) and Daylight Savings, or Summer Time, changeover settings. There are a number of other settings that may be important to your application, however local time offsets are normally fundamental requirements. For a complete list of setup menus, see Table 6.1.

There are two available methods for configuring the 1084B/C: (1) Using the lower row of keys on the front panel, and (2) remotely, using either the main RS-232C port or Option RS-232C port. *To configure Model 1084A, you must use the RS-232C port(s).* Both methods are described in this section. For complete information on configuring all clocks remotely through either serial port, please refer to Chapter 9, Serial Communication and Command Set.

At the end of each SETUP menu section are references to the corresponding RS-232C command(s) for configuring these functions.

Table 6.1 lists the various menus used to configure the operation of these clock models.

6.1 Setup Menus

| No. | Setup Menus | Setup Items |
|-----|--------------------|--|
| 1 | Main RS-232C | Main RS-232C Port Parameters and Broadcast |
| 2 | Local Hour & DST | Set Local Offset, Daylight Saving mode |
| 3 | Out Of Lock | Set Time Interval Before Alarm |
| 4 | Backlight | Set to ON, OFF or AUTO |
| 5 | System Delays | Set Timing Delay in Nanoseconds |
| 6 | Programmable Pulse | Set Mode, Pulse Width and Time Zone |
| 7 | IRIG-B Time Data | Set IRIG-B Time Zone and IEEE-1344 |
| 8 | Event/Deviation | Set for Event, or 1-PPS Deviation |
| 9 | Set Auto Survey | Set Survey mode |
| 10 | Position Hold | Set ON or OFF |
| 11 | Option Control | Set Main board and Aux. board options |

Table 6.1: Front-Panel Setup Menus

6.1.1 To Begin Configuring

Press the SETUP key to enter the clock configuration menus, starting with communication port parameters (Set Main RS-232?).



SETUP: Press the Setup key repeatedly to scroll through the main menus. Also, after pressing SETUP once, you can press the UP or DOWN keys to scroll the menus. In numeric data entry mode, press SETUP to move the cursor to the left.

ENTER: Press the Enter key to confirm changes made within SETUP menus. Generally, pressing ENTER also advances the next parameter, or returns to the previous menu level. In numeric data entry mode, press ENTER to move the cursor to the right.

UP: Press the UP key, within the SETUP menus, to adjust numerical values upward, or to scroll upward through the available menu choices. The UP key also assists in navigating through main Setup Menus in normal order.

DOWN: Press the DOWN key, within the SETUP menu, to adjust numerical values downward, or to scroll downward through available menu choices. Also assists in navigating through main Setup menus in reverse order.

6.1.2 Numeric Data Entry Mode

Numeric data entry mode is activated anytime you enter a menu that requires a change in numerical value and press either the UP or DOWN key to change the digit value. When in this mode, the function of the SETUP and ENTER keys change to give left and right cursor control.

6.1.3 Default Firmware Settings

When shipped from the factory, and unless specified otherwise, all models will be configured with default settings. Most users elect to modify the clock settings to fit their locale and desired operation. Default settings are listed in Table 6.2.

| Menu Item | Default | Menu Item | Default |
|------------------|-----------------|--------------------|-----------------|
| Main RS-232 | 9600, 8, N, 1 | Local Offset & DST | none, OFF |
| Out-of-Lock | 01 min. | Backlight | Auto |
| System Delays | 60 ns | Prog Pulse | Sec. per Pulse |
| IRIG-B Time Data | UTC, 1344 OFF | Event/Deviation | 1 PPS Deviation |
| Auto Survey | Power On Survey | Position Hold | ON |
| Option Control | None | – | – |

Table 6.2: Default Firmware Settings

6.1.4 To Exit Setup Menus

To exit any configuration menu without saving, press any of the upper row of keys before pressing ENTER (which installs a new value). To return to the configuration menus, press SETUP again. If you make a configuration error, you can scroll through the menus again and press ENTER when you find the menu you want to change.

6.2 Setting the Main RS-232C Port

Press SETUP key to configure the main RS-232C port, and press the ENTER key to begin setting up the RS-232C port parameters (See Figure 6.1). To set up the broadcast mode, press SETUP and skip to Section 6.2.2 below.

NOTE: port settings may not be changed 1084A series clock since it does not have a keypad, and there are no port setting commands.

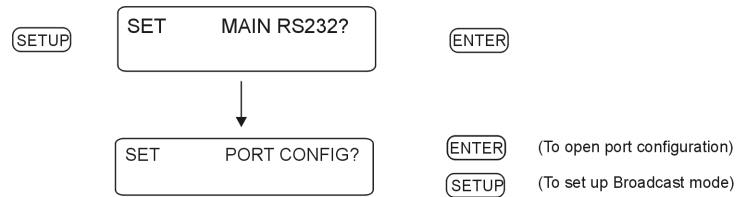

Figure 6.1: Main RS-232C Setup

6.2.1 Setting Port Parameters

The “Set Port Config” menu allows you to configure any of the RS-232C port parameters from the front panel. Use the UP and DOWN keys to adjust the parameter values. *RS-232C: Port parameters may not be changed from RS-232C ports. They may only be changed with Models 1084B/C series clocks from the front panel.*

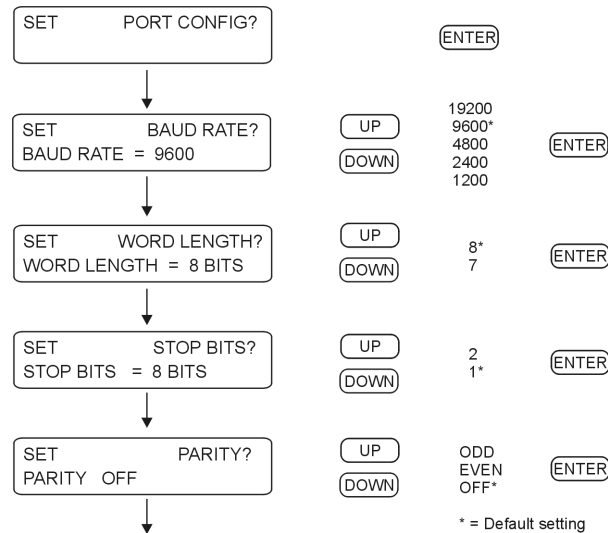

Figure 6.2: Port Parameter Setup

6.2.2 Setting the Broadcast Mode from Main RS-232

The “Set Broadcast Mode” menu allows you to configure any of these clock models to broadcast ASCII time/date-related data from the available RS-232C ports. With the UP/DOWN keys select the desired broadcast mode and press ENTER to immediately start the broadcast. *RS-232C: see Section 9.2.1.*

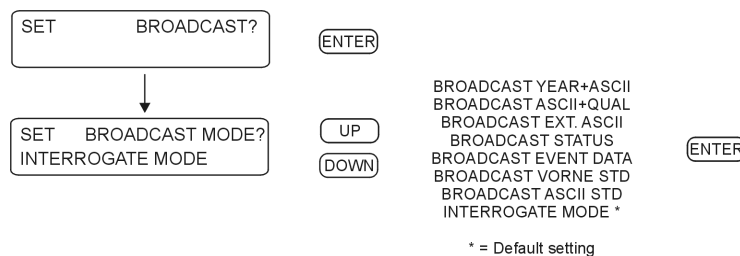

Figure 6.3: Broadcast Setup

6.3 Set Local Hour

Use “Set Local Hour” to set the offset in time from UTC to your locale and any Daylight Saving settings if they apply. Offsets may be adjusted in 15-minute increments, up to plus or minus 12 hours. Daylight Saving is adjusted for start and stop times, based on month, week of month, day and time of day. Use this menu to set up basic DST adjustment. *RS-232C: see Section 9.2.4.*

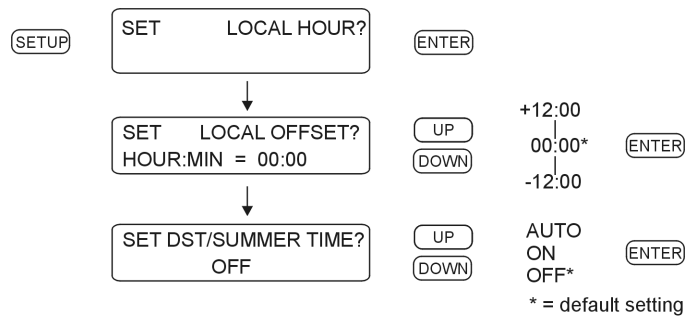

Figure 6.4: Local Hour Setup

6.3.1 Set Daylight Saving Time (DST)

For automatic changeover, use the AUTO setting explained above. Make sure to determine the changeover requirements in your locale before trying to adjust these clock settings. The default setup is for North America, where DST begins on the second Sunday of March at 2 am and ends on the first Sunday of November at 2 am. Go through each setting and verify that the settings are valid. To adjust and install values, press the UP/DOWN keys to adjust the desired value and ENTER key to install that value and proceed to the next setting. *RS-232C: see Section 9.2.4.*

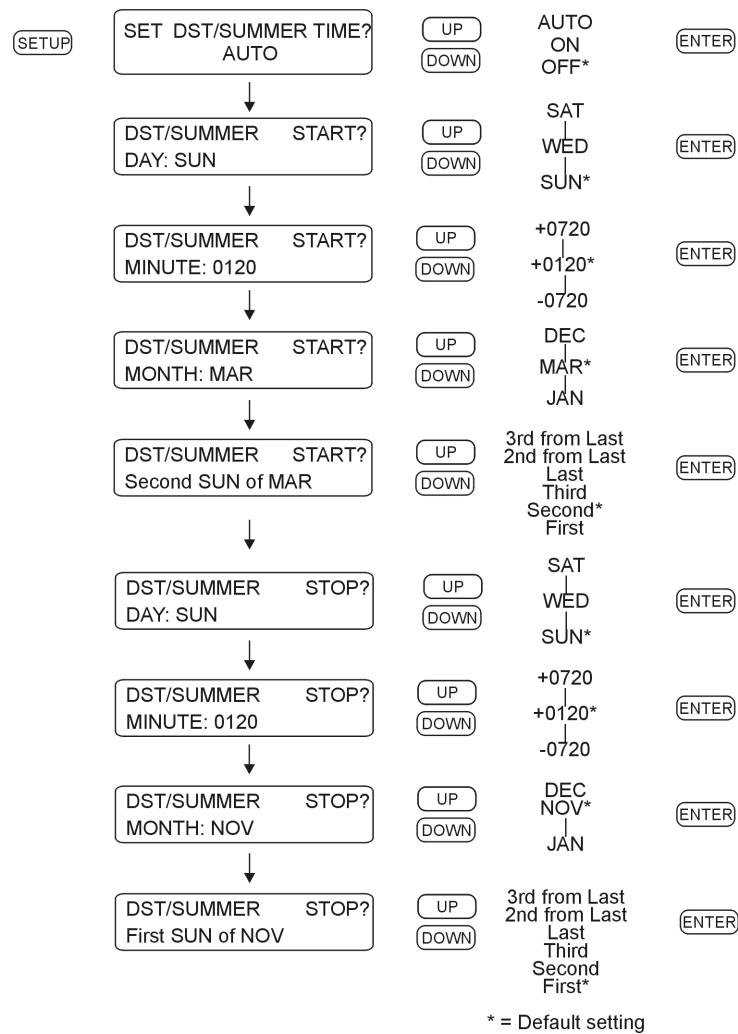

Figure 6.5: Auto Daylight Saving Setup

6.4 Set Out of Lock

Use the “Set Out of Lock” feature to control how the clock responds to an out-of-lock condition. Out of Lock means that the GPS receiver in the clock is no longer tracking any satellites and that the time may drift according to characteristics of the internal clock and environmental conditions. Adjust these settings so that, in the event of an out-of-lock condition, you will be notified in a reasonable amount of time. The default setting is for the clock to alarm after being unlocked for a period of one minute. Unlocked indications include the red UNLOCKED LED being ON, and the Out-of-Lock relay switching to the unlocked condition. *RS-232C: see Section 9.2.12.*

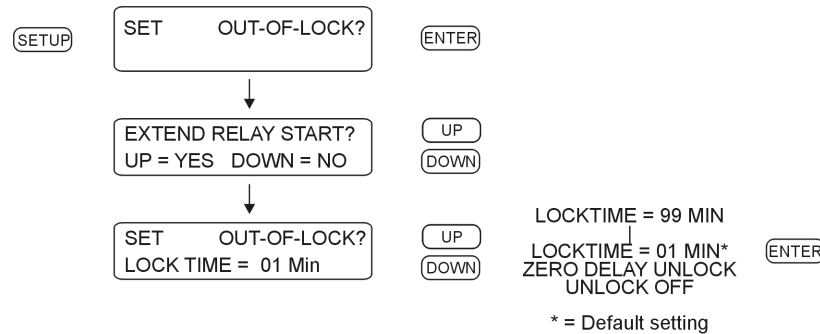

Figure 6.6: Out-of-Lock Setup

Extend Relay Start means that the clock will extend the time that the clock is not considered stabilized, the unlocked LED is lit, and the out-of-lock relay indicates an out-of-lock condition. Choose NO for the standard (shorter) indication, or YES to lengthen the out-of-lock indication to approximately 5 minutes under good satellite reception. Note that when choosing the extended relay start condition, the clock may be tracking sufficient satellites to be considered “locked” however it does not indicate that it is until completing the internal counting function.

6.5 Set Back Light

If the optional back light (Option 01) is installed in the clock, use the “Set Back Light” menu to configure how the back light operates. If back light is not installed, then the “Set Back Light” menu will have no effect. Settings are either (1) Back Light OFF, (2) Back light ON, or (3) Back light AUTO. In the Auto setting, the back light will operate for approximately 30 seconds before switching OFF. *RS-232C: see Section 9.2.5.*

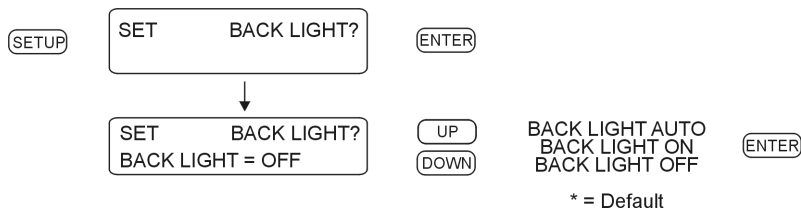

Figure 6.7: Back Light Setup

6.6 Set System Delays

Use the “Set System Delays” menu to set the delay in time for the GPS signal received at the GPS antenna to reach the GPS receiver. The delay in nanoseconds (10^{-9} seconds) is a product of the length of the cable and the its velocity factor. Without compensating for the cable delay, the time would be slow by this amount. *RS-232C: see Section 9.2.11.*

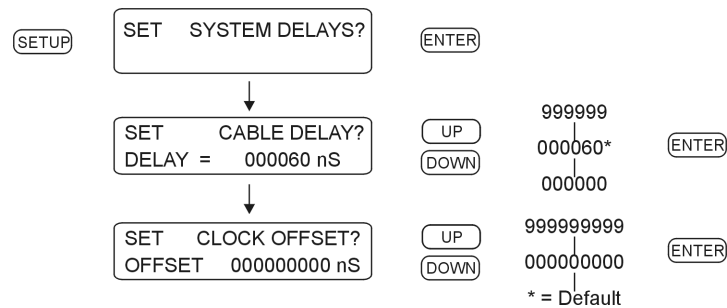

Figure 6.8: System Delay Setup

6.7 Set Programmable Pulse Mode

Use the “Set Prog. Pulse” menu to set up one of the many pulse modes available for broadcasting a pulse from P2 (see Table 5.1 and Figure 5.1) at a predetermined interval or rate. Also, there is a “pulse-per-day” mode and a “pulse-per-year” mode. Programming includes adjusting the pulse width, from a minimum of 10 milliseconds to 600 seconds, depending on the application, and configuring the pulse to occur at either UTC or Local time. *RS-232C: see Section 9.2.10.*

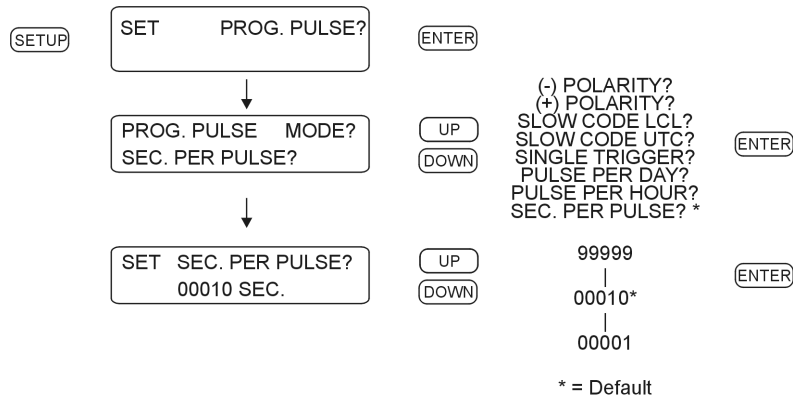

Figure 6.9: Programmable Pulse Setup

6.7.1 Entering Numerical Values

When installing numerical values first use the UP/DOWN keys to change the digits and then the SETUP and ENTER to move the cursor left or right. Then, use the UP/DOWN keys as before to change digits. To complete the installation after you have configured the numerical value, keep pressing the ENTER key to move the cursor to the right and exit the menu.

6.7.2 Prog Pulse – Seconds–Per–Pulse Mode

Use the Seconds–Per–Pulse mode to generate a pulse every X number of seconds, from 1 to 60,000 seconds, and a Pulse Width of from 10 milliseconds to 600 seconds. Refer to Section 6.7 above for additional detail on the Programmable Pulse mode. *RS-232C: see Section 9.2.10.*

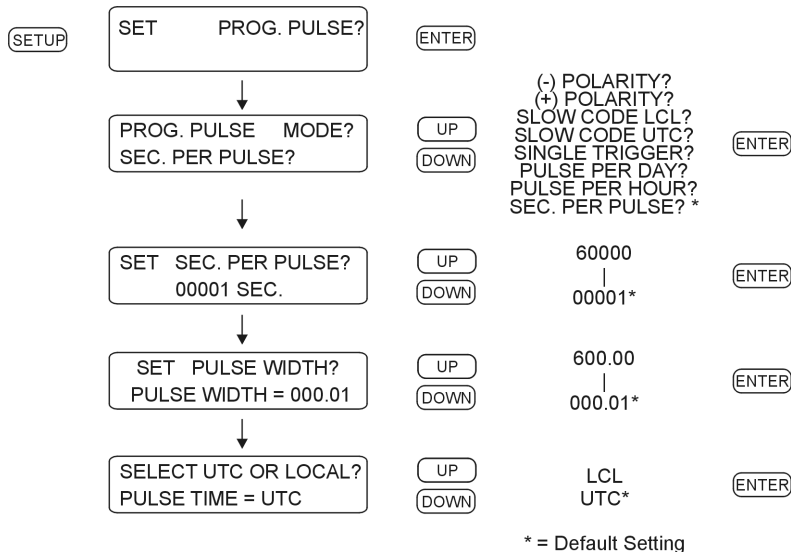

Figure 6.10: Seconds–Per–Pulse Setup

6.7.3 Prog Pulse – Pulse–Per–Hour Mode

Use the Pulse–Per–Hour mode to generate a pulse every hour, at the number of specified seconds (from 0 to 3599 seconds) after the hour. Refer to Section 6.7 above for additional detail on the Programmable Pulse mode, and Entering Numerical Values. *RS-232C: see Section 9.2.10.*

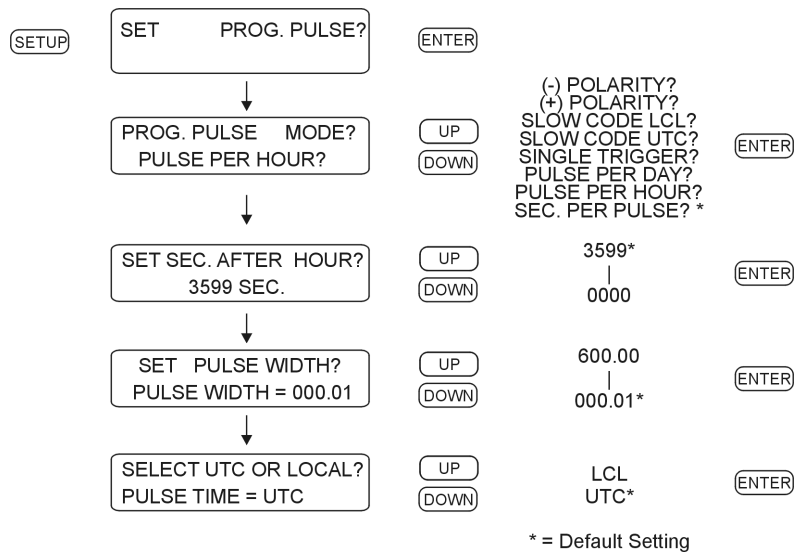

Figure 6.11: Pulse–Per–Hour Setup

6.7.4 Prog Pulse – Pulse-Per-Day Mode

Use the Pulse-Per-Day mode to generate a pulse every day, at the specified hour, minute, second and fractional seconds. Refer to Section 6.7 above for additional detail on the Programmable Pulse mode, and Entering Numerical Values. *RS-232C: see Section 9.2.10.*

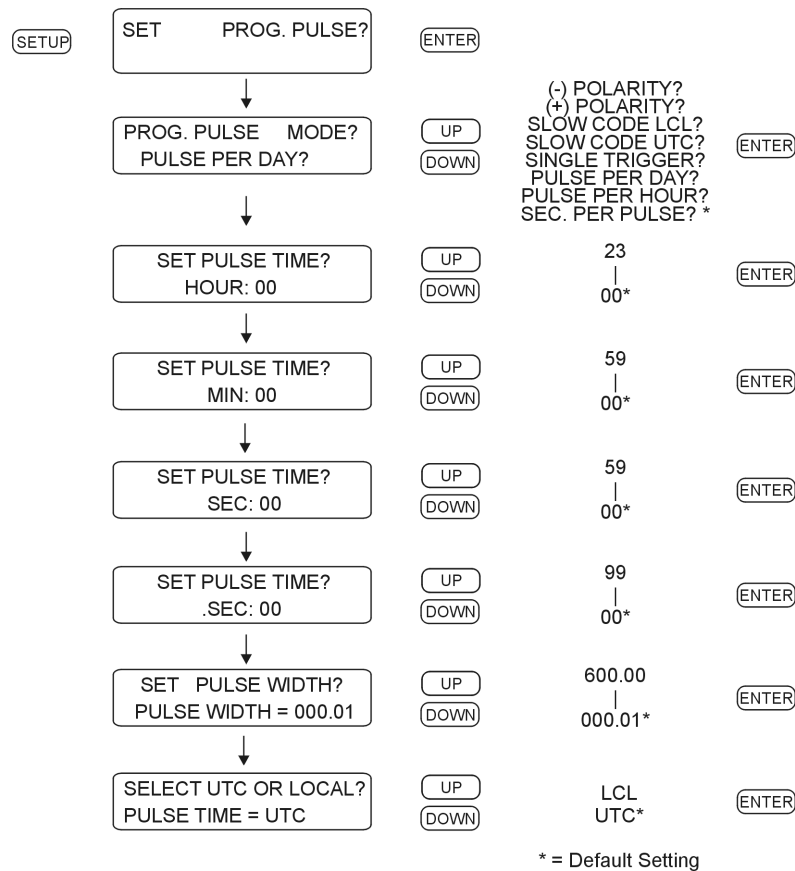

Figure 6.12: Pulse-Per-Day Setup

6.7.5 Prog Pulse – Single Trigger

Use the Single Trigger mode to generate a pulse once per year at the specified Julian Day, hour, minute, second and fractional seconds. For reference, many calendars indicate the Julian Day. Refer to Section 6.7 above for additional detail on the Programmable Pulse mode, and Entering Numerical Values. *RS-232C: see Section 9.2.10.*

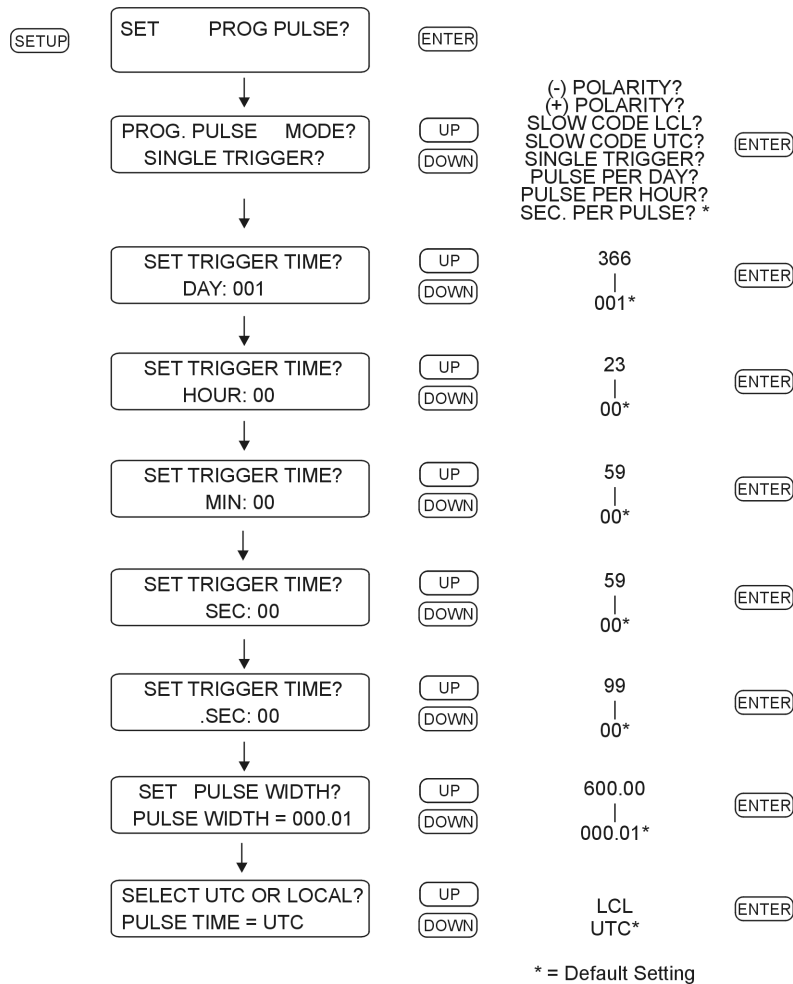

Figure 6.13: Single Trigger Setup

6.7.6 Prog Pulse – Slow Code

Slow code is a programmable pulse mode that causes the output voltage to be held high and go low for six seconds on the day, four seconds on the hour and two seconds on the minute. Note: Make sure to set the Pulse Polarity to negative for normal operation. See Section 6.7.7. *RS-232C*: see Section 9.2.10.

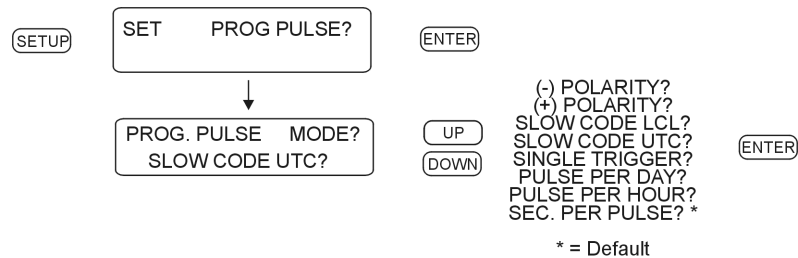

Figure 6.14: Slow Code Setup

6.7.7 Prog Pulse – Pulse Polarity

Use “Pulse Polarity” to change the pulse’s OFF-to-ON behavior as follows:

1. Positive: the voltage is held low (0 Vdc) when the pulse is off and transitions high (5 Vdc) when on.
2. Negative: the voltage is held high (5 Vdc) when the pulse is off and transitions low (0 Vdc) when on.

To set up the pulse polarity, first set up the programmable pulse mode (e.g. Single Trigger) and then go back into the Prog Pulse menu and set up the polarity separately. *RS-232C: see Section 9.2.10.*

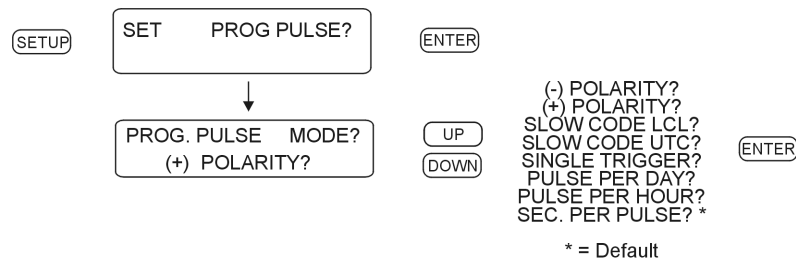

Figure 6.15: Pulse Polarity Setup

6.8 Set IRIG Time Data

Use the “Set IRIG Time Data” menu to adjust the time zone for *IRIG-B Time Data* between your locale and UTC, and to turn ON or OFF the IEEE-1344 extension. The IEEE-1344 extension controls some additional information contained in the IRIG-B time code (see Section 7.3.4). *RS-232C*: see Section 9.2.6.

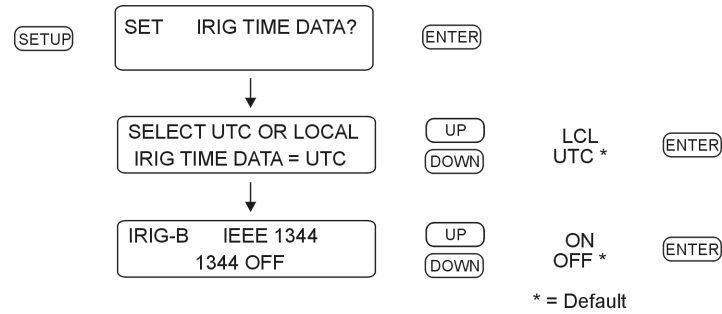

Figure 6.16: IRIG-B Time Data Setup

6.9 Setting the Event or Deviation Modes

Use the Event/Deviation Mode to capture an event (signal) at either P3 (standard I/O) or J6 (main RS-232C port). Configure for either event timing (up to 500 stored events) or one pulse-per-second (1 PPS) deviation, including sigma (see Section 8.2.3 for details on the principle of deviation measurement). *RS-232C*: see Section 9.2.2.

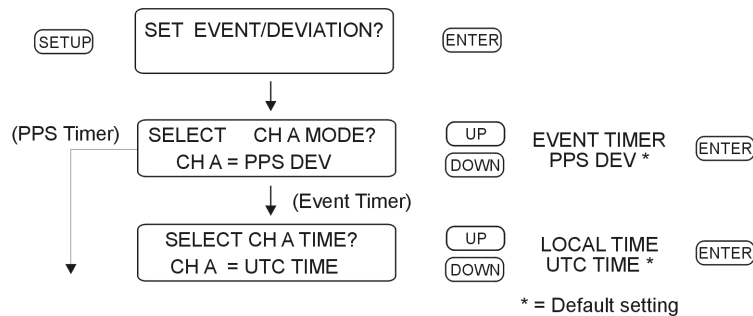

Figure 6.17: Event/Deviation Mode Setup

6.9.1 Arming the Event Input

When using P3, note that the event function continually arms itself for the next event until the buffer is full. When using the RS-232C port as the input, you must arm the event function for each event from the front panel or by using the AR command. To arm the Event Input from the front panel see Figure 6.18 below.

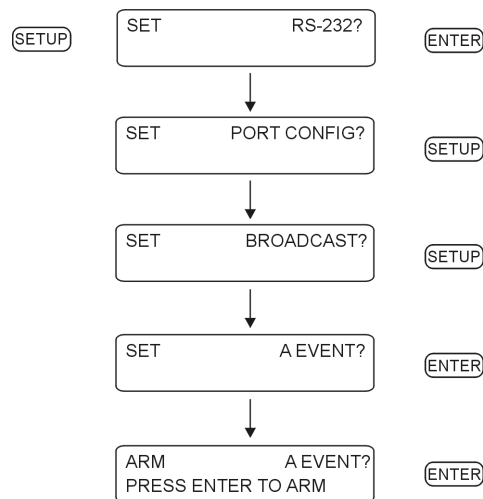

Figure 6.18: Arming the Event Mode From Front Panel

6.10 Setting the Auto Survey Mode

Use one of the Auto Survey modes to control how and when the clock determines position information. The accuracy of the position (and indirectly, time) is based on averaging the assigned number of position fixes surveyed, either during startup or by a single survey. At the conclusion of a survey, the clock is placed in Position Hold mode and the averaged position is placed into memory. If accurate position information is used, this results in a reduced standard deviation for the time data. *RS-232C: see Section 9.2.8.*

There are five Auto Survey modes available:

1. Turn Off Survey – halt the survey in progress
2. Single Survey – initiate a new survey at this time
3. Power-On Survey – initiate a new survey when the clock is powered on
4. Suspend Survey – pause a survey in progress
5. Resume Survey – resume a survey that was paused

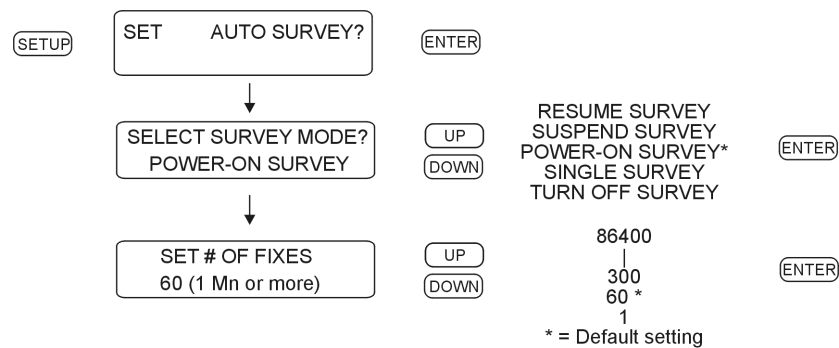

Figure 6.19: Survey Mode Setup

6.10.1 Number of Fixes

Auto Survey configuration presents a list of possible surveys from 1 to 86,400 seconds (approx. 24 hours). Surveys are listed as 1 (single fix), 60 (1 minute or more), 300 (5 minutes or more), 900 (15 minutes or more), 1800 (30 minutes or more), 3600 (1 hour or more), 7200 (2 hours or more), 14400 (4 hours or more), 28800 (8 hours or more), 43200 (12 hours or more), and 86400 (24 hours or more). To complete a survey, the GPS receiver must be tracking at least four satellites. If, during a survey, the number of satellites being tracked drops below four, the survey will pause until the GPS receiver again begins tracking four or more satellites. Then, the survey will resume computing positions until completion.

6.11 Set Position Hold ON or OFF

With Position Hold turned ON, the surveyed position is placed into memory and used for computing more precise timing solutions. With Position Hold turned OFF, the GPS receiver is placed in the Fix mode, calculating a new position approximately every second. In the Fix mode, the position information will appear to be changing each second as viewed on the clock display or being returned from the RS-232C port. *RS-232C: see Section 9.2.7.*

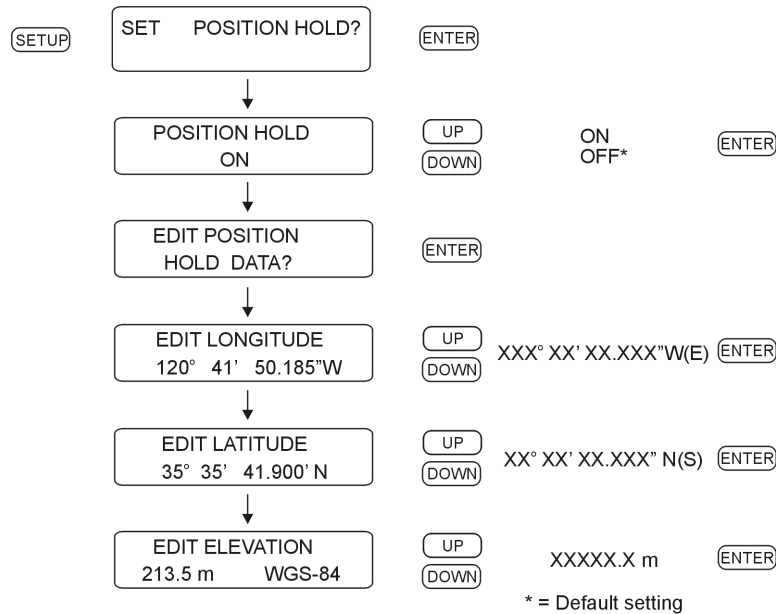

Figure 6.20: Position Hold Mode Setup

6.12 Set Option Control

Use the “Set Option Control” menu to configure any main board or auxiliary board option mounted in the clock. Some of these options require you to configure additional settings; information on configuring specific options is located in the Option List (see Appendix C), by option number. *RS-232C*: see Section 9.2.13.

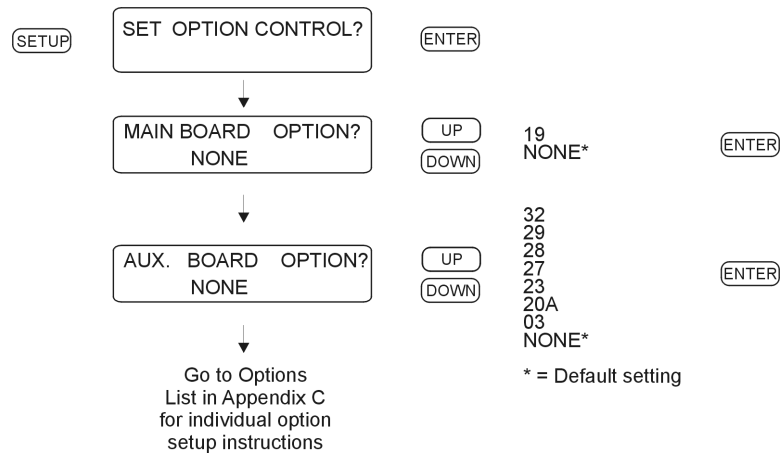

Figure 6.21: Option Control Setup

Chapter 7

Timing, IRIG-B and Pulses

7.1 Introduction

This section should help you with understanding, choosing and connecting the correct outputs from the Model 1084A/B/C series clocks to synchronize your external equipment, such as protective relays. It should also answer some basic questions, such as:

- What are the different types of IRIG-B, and what are the differences?
- How do you connect multiple devices to one timing output?
- How far can you transmit timing signals?
- What type of cabling and connectors should I use?

Often, questions arise about how many loads the output driver will support, and how they should be connected. Questions arise concerning how to connect cabling between the clock and the relay. Certain protective relays, or digital fault recorders may use a different style connector than available at the clock outputs. Finally, simple questions about which type of cabling (coax or a twisted pair) is best. This section should help to answer these common questions.

The steps involved in getting your devices synchronized to the GPS are fairly simple and should not take long to complete. To expedite the process, make sure that you know:

1. the type of timing signal each piece of equipment requires, and
2. how to enable the equipment to receive the timing signal.

Various methods are used to configure equipment for IRIG-B including setting a physical jumper, or setup program. Some equipment can auto detect the timing signal, so that nothing else is required, other than connecting the cable.

7.2 Timing Output Description

When viewing the rear panels of the Model 1084A/B/C, you will see that there are a number of different types of connectors as illustrated in Figure 7.1. Generally, there is a power inlet connector, a GPS antenna connector, two DB-9 serial connectors (one is an optional RS-232 port), two SPDT relay connectors and three timing outputs. When required, there is a space for an optional fiber optic port in which a type ST connector may appear. Finally, the Model 1084A/B/C series clocks also have an option plate that is replaced by several auxiliary board options.

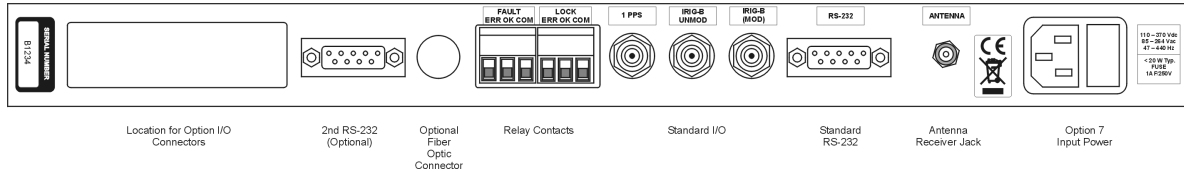

Figure 7.1: Rear Panel Descriptions

7.2.1 Standard Inputs/Outputs

All of these models have three, BNC female connectors that can supply timing signals to external equipment. One of these connectors (P3) may also be configured for an event/deviation input. Two of the outputs are designed for digital signals and one for analog. Signals supplied to the digital drivers include unmodulated IRIG-B, 1 pulse per second, and programmable pulse. The third connector is set up for a modulated IRIG-B only.

7.2.2 Digital Drivers

Each of the digital outputs is driven by a CMOS 74HC126 quad driver capable of supplying 75 mA at 5 Vdc, which may be fanned out to a number of devices. To determine the maximum number of devices that the digital drivers can support, you will need to determine the load current, or input impedance, for each device. For example, if the IED timing input signal (e.g. IRIG-B003) requires 10 mA, one output channel should be able to support 7 identical devices.

7.2.3 Analog Driver

The 1084A/B/C has one analog driver available exclusively for *modulated IRIG-B signals*. Additional analog drivers may be added as options (e.g. Option 03, 27, 29). The analog driver is basically a push-pull audio design (MMBT4401/4403), which supplies a 4.5 Volt peak-to-peak (10 Vpp on Option 03) signal through a 19.6-ohm source resistor to IED's. As the load current increases (by adding external IED's), more voltage is dropped across the clock source resistor and the drive voltage decreases. Matching the modulated IRIG-B output voltage to the IED input is sometimes critical, so it is important to match the modulated IRIG-B peak-to-peak voltage to within the specified range of the IED. Table 7.1 shows how the actual drive voltage varies with increasing load current. For IED's with a restricted input range, it may be necessary to match the available drive voltage to the IED through a small dropping resistor.

| Drive Current, mA | Actual Drive Voltage, Vpp |
|-------------------|---------------------------|
| 0 | 4.5 (no load) |
| 1 | 4.48 |
| 10 | 4.3 |
| 100 | 2.54 |

Table 7.1: Drive Current vs. Voltage

7.3 Output Signal Description

All models can provide three different digital signals and one analog signal. Digital signals consist of unmodulated IRIG-B, 1 PPS and Programmable Pulse. With option cards installed, many other digital signals are available; see Appendix C for output options with listed digital signals. Most of the information in this section is devoted to IRIG-B, its specifications and differences.

1 PPS is mainly used for synchronization, in conjunction with another timing signal. It occurs once each second and has a duration (pulse width) of 10 milliseconds. Programmable pulse modes are similar to 1 PPS only they have an adjustable period and pulse width. Programmable pulse modes include, seconds per pulse, pulse per hour, pulse per day, single trigger (once per year) and slow code.

7.3.1 IRIG-B Description

IRIG-B is a complete serial time code that occurs once per second and is defined by four terms: Format, Modulation Frequency, Frequency Resolution, and Coded Expressions (e.g. for B120, B = Format B, 1 = sinewave, 2 = 1 kHz, and 0 = BCD, CF and SBS). The Model 1084A/B/C clocks allow only Format B with four variations as seen in Table 7.2. Other IRIG formats are A, D, E, G, and H. Note that with the newer IRIG Standard 200-04, two of the designations have changed: the older B000 has become B004 and B120 has become B124.

| Designation Old/New | Signal Type | Code Components |
|---------------------|---------------------------------------|------------------------------|
| B000/B004 | Pulse width code, No carrier | BCD _{TOY} , CF, SBS |
| B003 | Pulse width code, No carrier | BCD _{TOY} , SBS |
| B120/B124 | Sine wave, amplitude modulated, 1 kHz | BCD _{TOY} , CF, SBS |
| B123 | Sine wave, amplitude modulated, 1 kHz | BCD _{TOY} , SBS |

Table 7.2: IRIG-B Time Code Types Available

There are three functional groups of bits in the IRIG-B time code, in the following order: - Binary Coded Decimal (BCD), Control Function (CF) and Straight Binary Seconds (SBS). The BCD group contains only time information including the seconds, minutes, hours and days, recycling yearly. The CF group contains other time-related information including year, time quality, leap year, pending leap seconds and parity. The SBS consists of the total elapsed seconds, recycling

daily. Position identifiers separate the various components of the IRIG-B time code.

7.3.2 Modulated and Unmodulated IRIG-B

Figure 7.2 illustrates the primary differences between modulated and unmodulated IRIG-B. You will notice that the while modulated IRIG-B is distinctive because of the 1 kHz sinewave carrier, it is similar to unmodulated IRIG-B since the peak-to-peak values of the carrier follow the same form as the digital waveform, where the information is contained.

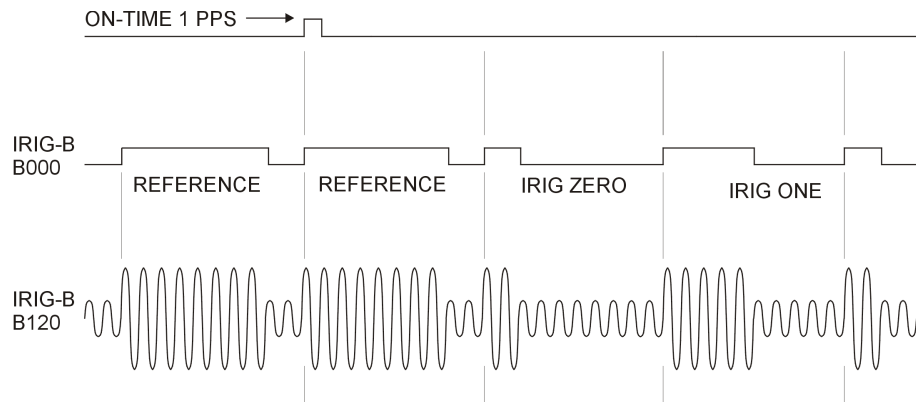

Figure 7.2: IRIG-B Waveforms

The IRIG-B time code consists of 100 bits produced every second, 74 bits of which contain various time, date, time changes and time quality information of the time signal. Consisting of logic ones, zeros and position identifier bits, the time code provides a reliable method of transmitting time to synchronize various equipment.

7.3.3 Available IRIG-B Signals

All clocks can provide IRIG-B that follows four type codes: two with unmodulated IRIG-B and two with modulated IRIG-B. The two signal types for each group are because of the IEEE 1344 extension, or CF portion of the time code. Turn the IEEE 1344 extensions ON or OFF, the differences depicted in Table 7.3, by configuration through the front panel keys (Models 1084B/C) or through the serial port(s).

| IRIG-B Type | 1344 ON | 1344 OFF |
|-------------------|---------|----------|
| Unmodulated, B00X | B000* | B003 |
| Modulated, B12X | B120* | B123 |

Table 7.3: IRIG-B Code Designations

*The IRIG Standard 200-04 has changed the designations so that Year information is now considered part of BCD and denoted as BCD_{YEAR} . This means that what was formerly considered B000 and B120 would now be denoted as B004 and B124.

7.3.4 IRIG-B IEEE 1344 Extension

As mentioned above, the IEEE 1344 enables extra bits of the Control Function (CF) portion of the IRIG-B time code. Within this portion of the time code, bits are designated for additional features, including:

- Calendar Year (old method, now called BCD_{YEAR})
- Leap seconds, and leap seconds pending
- Daylight saving time (DST), and DST pending
- Local time offset
- Time quality
- Parity
- Position identifiers

To be able to use these extra bits of information, protective relays, RTU's and other equipment receiving the time code must be able to decode them. Consult your equipment manual to determine if the IEEE 1344 feature should be turned ON in the clock. To view details of the IEEE Std 1344-1995, please check with the IEEE.

NOTE: To download a copy of the IRIG-B 2004 specification, please use the link to the Arbiter web site.

http://www.arbiter.com/catalog/timing_freq_index.php and click on IRIG-B.

7.3.5 1 Pulse-per-Second (1 PPS)

A one pulse-per-second timing output signal is very simple in concept. It is a digital bit transmitted every second with a pulse width of 10 milliseconds. Probably the most critical part of this signal is that the rising edge is “on time” as compared with the signal from the Global Positioning System (GPS). When configured from any of the TTL/CMOS (5-volt) drivers, it has the same drive power as the IRIG-B and the Programmable Pulse. See Figure 7.2 for a comparison between unmodulated IRIG-B and 1 PPS.

7.3.6 Programmable Pulse (PROG PULSE)

Models 1084A/B/C series clocks have an independent programmable pulse feature that requires some jumper and firmware configuration. Models 1084B/C may be configured from the front panel and 1084A must be configured through the RS-232 port. Programmable pulse modes include setting the pulse width and time zone. To configure, please see Sections 5.2 and 6.7.

7.4 Connecting Outputs

All clocks come equipped with BNC female connectors, however if you are using twisted pair cabling, you can use a BNC breakout. See the reference below¹, or other similar adapter.

NOTE: If using a shielded, twisted-pair cable (like Belden 8760), DO NOT connect the cable shield at the clock. Always connect a cable shield at the receiving equipment (IED) grounding point.

¹Pomona Electronics, www.pomonaelectronics.com, (800) 444-6785, (425) 446-6010, part no. 4969 and 4970

| Prog Pulse Mode | Configured Feature |
|------------------------|--|
| Seconds Per Pulse | X number of seconds between pulses, 0 – 60,000 |
| Pulse Per Hour | Number of seconds after each hour, 0 – 3599 |
| Pulse Per Day | Hour, Minute, Second, Fractional Seconds |
| Single Trigger | Day, Hour, Minute, Second, Fractional Seconds |
| Slow Code | ON or OFF |
| Pulse Polarity | positive or negative-going pulse |

Table 7.4: IRIG-B Code Designations

7.4.1 Attaching Cables to Screw Terminals

Some of the option boards mounted in the Model 1084A/B/C series clocks have screw terminals instead of BNC connectors to connect wiring. To mount wiring to screw terminals, prepare the twisted pair cable by stripping back at least 1/4” of the insulation and any shielding, and tin the bare wire. Tighten the screws down on the wire. Do not ground the shield to the Arbiter clock, rather ground it at the receiving end.

7.4.2 How Far Can I Run IRIG-B Cabling?

Before laying cable to transmit IRIG-B over long distances, take time to consider the following factors: (1) resistive losses in cabling, (2) electromagnetic interference, (3) propagation delays and (4) installation and maintenance costs.

For details on distributing IRIG-B signals over long distances, see application note, AN101, Distributing Timing Signals in a High-EMI Environment. Download file appnote101.pdf at the following link:

<http://www.arbiter.com/ftp/datasheets/>

For important considerations about IRIG-B connections, distribution of signals and accuracy, download the file,

IRIG-B_accuracy_and_connection_requirements.pdf at the following link:

<http://www.arbiter.com/ftp/datasheets/>.

7.4.3 Synchronizing Multiple IED’s From One Masterclock Output

In many installations, master clock signals are “fanned out” to a number of devices. This method makes more efficient use of the clock synchronizing capability since the clock drivers are designed to handle multiple loads. The exact number of possible loads must be determined from the input impedance of each connected IED. For example, if the input impedance of the IED is 5 kilohms, determine the device current (I) as follows:

$$(7.1) \quad I = V \div R_{dev} = 5 \text{ Volts} \div 5000 \text{ Ohms} = 0.001 \text{ Amps (1 mA)}$$

If you were to connect ten of the same IED's to the same output, then the total current drawn would be $10 \times 0.001 \text{ A} = 0.01 \text{ A}$ (10 mA).

7.4.4 Connecting Unmodulated IRIG-B

To drive multiple loads from one unmodulated IRIG-B output, make sure that the loads are wired in parallel. Some technicians might call this “daisy-chaining”, however the idea is to drive all of these loads in parallel from the single output. It is much simpler to connect loads to unmodulated IRIG-B than for modulated, because all of the loads are driven at the same voltage.

To determine load current for one Unmodulated IRIG-B output:

1. determine the number of loads to be connected to a single clock output
2. determine the impedance (or resistance) of each load
3. calculate the load current for each device ($I_{dev} = 5V \div R_{dev}$)
4. sum up all the load currents for the total current for one clock output.

Another method is to determine the lumped impedance of all of the connected IED's in parallel. Then, determine the overall current by dividing the drive voltage (5 V) by the computed lumped impedance value. This current should not exceed 75 mA.

7.4.5 Connecting Modulated IRIG-B

The total load capacity for the modulated IRIG-B driver depends on the type and number of loads. The main difference in computing the load capacity for modulated IRIG-B and unmodulated IRIG-B is that most of the modulated IRIG-B decoders are fairly sensitive to the peak-to-peak voltage. When adding loads, the clock's modulated driver produces more current, which is passes through the internal source resister, dropping the available output voltage. The open circuit voltage (i.e. with no loads) is approximately 4.5 Vpp, so any connected loads will cause the available voltage to drop. It is a simple task to compute the available output voltage (Vpp) with a known current.

$$(7.2) \quad V_{pp} = 4.5 \text{ Vpp} - I \times 19.6 \text{ Ohms}$$

Therefore, if you had 10 mA of load current (I load) the available voltage (Vpp) would be 4.304 Vpp. If the load current equals 100 mA, then the available voltage would be 2.54 Vpp. So, you can see how the increasing load current (i.e number of loads) affects the available drive voltage at the clock output. See also Table 7.1.

7.4.6 Wire Losses

Another factor affecting the available voltage is the resistive losses through the cabling. Wire has a certain resistivity associated with it that is determined by its metallic composition, and resistance determined by the diameter and length. For example, single-strand, 22 AWG (bare, enamel-coated) copper wire has a resistance of approximately 19.6 ohms per 1000 feet. To compute the loss we must include both wires in the connection, signal and return. For coaxial cabling, the resistance of the center conductor is rated differently than the shield. For a twisted pair, both of them should essentially have the same resistance per cut length. If we use a twisted pair of 22 AWG (copper as above), then the available voltage (at 100 mA of current) for 500 feet of wire including the source resistor would be:

$$(7.3) \quad V_{pp} \text{ available} = 4.5 - I \times 19.6 \text{ source} - I \times 19.6 \text{ wire} = 0.58 V_{pp}$$

So, you can see that most of the drive voltage is lost with 100 mA of current and 500 feet of 22 AWG twisted pair transmission line; this includes the voltage losses at the source resistor. 0.58 Vpp may very likely not be detected by the decoder in most IED's. Remember to make your cable runs as short as possible, to use a larger diameter cable, and to carefully distribute the loads.

7.4.7 Voltage Matching for Modulated IRIG-B

With modulated IRIG-B, it was mentioned that certain decoders are very intolerant of drive voltage variation. If the IED specification says that the acceptable voltage range is 3.3 Vpp \pm 0.5 volt, and the available voltage is high, then you must reduce the voltage using a dropping resistor (R_{drop}). The value of the dropping resistor is determined by dividing the difference voltage (V_{diff}) by the device current (I_{dev}). For example, suppose that the available voltage is 4.5 Vpp, the (nominal) acceptable voltage is 3.3 Vpp, and the device current is 10 mA. Determine the dropping resistor value.

$$(7.4) \quad R_{drop} = V_{diff} \div I_{dev} = (4.5 - 3.3) \div 0.01 = 120 \text{ Ohms}$$

The Power dissipation (P) is:

$$(7.5) \quad P = I^2 R = 0.01^2 \times 120 = 0.012 \text{ Watts}$$

In this example, an eighth-watt resistor should work fine.

For a voltage that is too low, the modulated IRIG-B signal level must be increased by some other means, such as (1) distributing the load differently to reduce the current (raising the available voltage), (2) by reducing the cable loss by increasing the wire size, or (3) by using an amplifier.

7.4.8 Cable Delays

Electromagnetic waves travel at the speed of light (C) in free space or vacuum and a fraction of that speed through cabling. The speed of an electromagnetic wave in free space is given by Constant 7.6.

$$(7.6) \quad C \approx 9.84 \times 10^8 \text{ feet/second}$$

Since electromagnetic waves travel slower through any cable, cable manufacturers normally specify cable with a velocity factor (VF), which is a percentage of the speed of light in free space, and characteristic of the specific cable. The velocity factor for the RG-6 cabling used by Arbiter Systems for GPS antenna connections, is about 83% of C. Most transmission lines have velocity factors in the range of 65% to 97%. Using these values you can determine the actual time delay in your cable distribution system and compare it to your required accuracy. As an example, 840 feet of RG-6 cable (with a velocity factor of 83%) would delay the timing signal by one microsecond. For IRIG-B timing applications, these delays may not be important, compared to other criteria. Otherwise, you would be forced to compensate for the time delay using another method, such as advancing the timing output or placing another master clock at the remote site.

7.4.9 Solutions

There are many solutions to providing an accurate timing signal to equipment in distant locations. However, the most satisfying solution may not be to string cabling for hundreds of meters. The costs associated with installing and maintaining cabling over a wide area may be unsatisfactory. Since the GPS is so pervasive, it may prove to be less costly to install another clock at a distant location, which would also improve accuracy and provide redundancy. Before installing cabling over a wide area, be sure to first examine all the possibilities.

Chapter 8

Relay Contacts and Event Inputs

8.1 Relay Contacts, Out Of Lock and Fault

8.1.1 Introduction

Model 1084A/B/C has two sets of relay contacts; both are a Form-C single-pole, double-throw (SPDT) relays. One is used for indicating an out-of-lock condition and the other indicates a fault condition.

8.1.2 Relay Operation

Relay contacts are set up for out-of-lock indication by default, so that there will be a contact closure if the clock loses synchronization with the GPS. The relay contacts indicate an out-of-lock condition based on a setting available by configuration through the front panel or the RS-232 interface. Out-of-Lock settings are (1) Unlock OFF, (2) Zero Delay Unlock, and (3) 1 to 99 Minute Delay for unlock. The relay also provides a fail-safe indication by switching to the faulted condition when the clock loses power.

Occasionally, these relays may be used for other purposes by modification. One possibility is to use the Programmable Pulse feature for periodic contact closures. Use caution when modifying the use of the relay contacts as it is a mechanical Form C type and has a limited lifetime of approximately 100,000 cycles.

8.2 Event Inputs

8.2.1 Event Timing Input

When configured for event timing, the 1084A/B/C series clocks can provide one input channel with 0.1 microsecond resolution. This channel is primarily used for synchronization via the RS-232 port with an external computer or other type of device. It may also be used to time an external 5 V CMOS signal applied to P3; see Figure 5.1 and Section 5.3.

Data for individual recorded events can be recalled using either the Event/Deviation key or via the RS-232C interface (see Section 9.2.2). Data for each event will be retained until it is retrieved using one of these two methods. Thus, if no event data points are retrieved, recording will be suspended when the total number of events reaches 500. As soon as data is retrieved for a recorded event, its address (000 - 499) is made available for data corresponding to a new incoming event.

8.2.2 Event Timing Latency

Event data are recorded using a high-speed capture circuit operating with a 4 MHz time-base. Latency is limited by the interrupt processing speed of the clock's microcontroller, which in turn depends on its workload at the time the event is received. Since the workload varies from time to time, latency likewise varies. However, response time will, in general, never be less than a few hundred microseconds nor greater than 10 milliseconds.

8.2.3 Deviation Measurement

The Channel A input can also be configured to display measured event times as 1 pulse-per-second (1 PPS) deviation measurements. The intended purpose of the deviation measurement function is to allow comparison of an external 1-PPS signal to the clock's internal 1-PPS signal. The clock determines the mean time difference between the two signals, which can be displayed on the front panel or read via the RS-232 Interface.

8.2.4 Measurement Principle

The measurement technique employed for 1-PPS Deviation uses the same time determination and recording scheme used for Event Time measurement (refer to paragraph above), but makes the assumption that the input signal is periodic and continuous. Also, the operation of the circular memory buffer is modified somewhat, in that recording does not stop after the first 500 events; new Event Data is given priority over existing data, and will overwrite it. Since the incoming signal is at 1 Hz and the circular buffer holds 500 events per channel, each Event Time Record will be overwritten once every 500 seconds.

Once every second, the processor looks at the most recent group of 16 events. When computing deviation, it uses only the portion of the event data describing fractional seconds (e.g. values between 0.0000000 and 0.9999999 seconds). By normalizing the 16 fractional-second values around 0.0000000, the range of results from the deviation computations will be centered on zero (-0.4999999 to +0.5000000 seconds). Statistical computations are then performed on the 16 values to determine their Mean and Sigma (Standard Deviation) values, which are then displayed on the front panel or output via RS-232.

8.2.5 Event Timer Input Channel Configuration

In order for the Model 1084A/B/C to receive a timing input, adjustments to both the hardware and software configuration may be required. The hardware configuration is described in Section 5.3.

8.2.6 Firmware Setup

Reconfiguration of the firmware may also be required to allow measurement and display of event time data and/or 1-PPS Deviation. See Figure 6.17 for detail on configuring the Event/Deviation parameters from the front panel. See Section 9.2.2 for details on using the RS-232C interface to manage event/deviation recording.

8.2.7 Displaying Data

Event and Deviation data can be accessed from either the front panel or via RS-232 commands. The following paragraphs describe the steps required to access data using the front panel EVENT/DEVIATION key. Press the EVENT/DEVIATION key and the display will enter a circular scroll. It begins by showing the data (if any is present) for Channel A, as previously configured for Event Recording in Figure 6.17 and Section 9.2.2. The readout will display one of the records (000 to 499) and associated event times, using the following format:

```
CH A EVENT #nnn TIME
ddd:hh:mm:ss.ssssss
```

Where:

“nnn” = event number (000 to 499)

“ddd” = day of year of the event (1 to 366)

“hh” = hour of the event (00 to 23)

“mm” = minute of the event (00 to 59)

“ss.ssssss” = second and fractional seconds of the event (e.g. 59.9999999)

Press the UP or DOWN key to scroll through all events presently stored in the event time buffer. After exiting and re-entering the event display mode, the first event data displayed for a given channel will correspond to the same event number as was last displayed for that channel. However, the data itself may be changed if it has been overwritten.

To clear the event buffer, press the EVENT/DEVIATION key again, while viewing Event data. This will cause the display to issue the following prompt:

```
CLEAR EVENT (A)?
UP=YES DOWN=NO
```

NOTE: If the event capture channel is not configured for event time recording, it will not display the CLEAR EVENT prompt.

Clocks display the CLEAR EVENT prompt only if the event capture channel was previously configured for event time recording. Press ENTER during this display to delete all of the records in the event buffer, and to allow recording of new event times, starting with event number 000.

If the event capture channel is configured for 1-PPS Deviation, the readout will display the deviation of the 1-PPS input signal. In this case, the readout display will have the format:

```
A 1 PPS ±XXXXX.XX μS
SIGMA: XXXXX.XX μS
```

Where:

1. The top number is the mean (average) value of the most recent 16 records in the event buffer, and represents the mean deviation (in microseconds) of the measured 1-PPS signal from the GPS 1-PPS signal. A negative number means the applied 1-PPS signal is early, i.e. before on-time, and a positive number means it is late, i.e. after on-time.
2. The bottom number is the standard deviation (sigma) of the values of the 16 samples.

8.2.8 RS-232C Event Trapping

The event capture channel of the Model 1084A/B/C can be configured to capture one or more events via the RS-232C Serial Interface. The time mark for a captured event will correspond to the leading edge of the start bit of the first character in the RS-232C signal. This event mode can be both armed and interrogated for data over the RS-232C interface, allowing automated synchronization of an external computer or system.

To perform event trapping via the RS-232C interface, the circuit must first be ARMED; that is, made ready to receive an event trigger. Only one event may be captured after every arming, but the events are stored sequentially in the event buffer in exactly the same manner as the normal event time mode, thereby allowing up to 500 events to be recorded.

8.2.9 Event Trapping Setup

Configuring the clock to trap events (incoming data) on the RS-232C interface requires making the configuration changes described in Section 5.3.

Arm the Event-Trapping circuit from the front panel using the SET RS-232 sub-menu from the SETUP key. This menu also provides for configuration of communications port parameters (e.g. baud rate, word length, etc.) to match those of the computer or equipment to be interfaced. The following steps are required to arm the Event Trapping circuitry from the front panel:

1. Press the following keys in order; SETUP > ENTER > SETUP > SETUP. The display should indicate the following:

SET A EVENT?

2. Press ENTER again and the display should indicate the following:

ARM A EVENT?

PRESS ENTER TO ARM

3. Press the ENTER button and the Event Input should be armed.

When the event occurs on the RS-232C port (i.e. the start bit of the next received character), the event data can be reviewed in the event mode exactly as any normally captured event would be. To capture further events, the circuit must be re-armed from the front panel or by using the RS-232 Command "AR."

Note that received commands are viewed as complete when the final character in the command is received. Control characters, such as carriage-return and line-feed, are ignored and may follow the "AR" command, but the start bit of the next character after the "R" (even if a carriage return) may trigger the event timer. For a complete list of RS-232C Event Mode commands, refer to Section 9.2.2.

Chapter 9

Serial Communication and Command Set

9.1 Introduction

Models 1084A/B/C series clocks have one main RS-232C port, and one optional RS-232C port. These are labeled RS-232C and Option RS-232C. When viewing the rear panel, the main port is nearest the antenna connector and the optional port is to the left of the Standard I/O connectors. RS-232C combines an RS-485 function in the same connector. *It is important to note that the Option RS-232C port does not have an RS-485 function, either RS-232C ports do not use flow control, and the RS-485 port functions in transmit only mode.*

Use the two serial ports interchangeably for separate functions. You may wish to interrogate the clock on one port for basic information (i.e to configure something) and at the same time be able to have the second serial port broadcasting a specific time code to a meter. While most recent substation equipment has standardized on the IRIG-B time code, some devices are designed to receive ASCII data through the serial port. Another common serial-port function is to connect a digital wall display to indicate the time.

9.2 Command Set

This section provides information for controlling and communicating with these clocks via the RS-232C serial interface. All of the RS-232C commands are functionally grouped into similar categories. For example, Section 9.2.1 lists all of the commands used to both set and retrieve the date and time in one of the standard formats.

Each command name and syntax is highlighted in bold at the beginning of each definition. Detailed information used to interpret the commands and responses follows each command heading. Sometimes the command is very short, such as the command to return the Local Time: TL. Other commands require a prefix or suffix with the letter command to specify them, such as to broadcast: Bn, where n equals an integer specifying the broadcast. For example, the command to start the ASCII Standard broadcast string at a rate of once per second, on Local time, from the main RS-232C port is B1.

When a command requests information from a clock, it returns the most current data available. Numeric data is returned as an ASCII string of numeric characters, with leading sign and embedded decimal point as needed. Strings are normally terminated with carriage return and line feed characters, however sometimes this is not the case. Enter any RS-232C command as written in these tables *without* pressing ENTER, or if programming, by sending a sequence of carriage-return/line-feed characters.

In this section, the syntax of each command follows the word "Command:" and is in bold font.

The following symbols and syntax are used:

␣ = Shorthand for carriage-return, line-feed
'U' = UTC Time
'L' = Local Time
soh = An ASCII character (start of header) = Hex 01
bel = An ASCII character = Hex 07
n = integer used for various numerical values (e.g. nnn in minutes)
yyyy = four digit year
ddd = Julian day-of-year
mm = month
hh = hour
mm = minute
ss = second

Underlines are used for clarity only and graphically represent the location of ASCII spaces.

9.2.1 Broadcast Mode Commands

Broadcast Mode – INTERROGATE (Broadcast OFF)

Command: **B0, O0**

B0 deactivates the RS-232C broadcast mode (resets to interrogate mode) on the main RS-232C port. O0 deactivates the RS-232C broadcast mode on the option RS-232C port.

Response: >

Broadcast Mode – ASCII STD

Command: **B1, O1**

B1 configures the clock to broadcast the time-of-day as ASCII standard data from the main RS-232C port. O1 configures the clock to broadcast ASCII standard data from the option RS-232C port.

Response: <soh>ddd:hh:mm:ss >

Broadcast Mode – VORNE STD

Command: **B2, O2**

B2 configures the clock to broadcast data formatted for Vorne large format time displays from the main RS-232C port. O2 configures the clock to broadcast from the option RS-232C port Vorne-formatted data. Refer to Arbiter Systems Application Note 103 for more information on using large format displays with Arbiter Systems' GPS clocks.

Response: 44hhmmss >(UTC/Local Time)
55ddd >(day of year)
11nn >(out-of-lock time)
bel (bel = Hex 07; sounds at the end of the time code)

The number and order of strings returned depend upon options ordered with clock (for example, see Option 28 in Appendix C, Options List, page 153):

Data is transmitted ahead of time, and the bel character is transmitted on time. When properly configured, the Vorne displays update simultaneously upon receipt of the bel character.

Broadcast Mode – EVENT DATA

Command: **B3, O3**

B3 configures the clock to broadcast from the main RS-232C port any event data at the time it is recorded. O3 configures the clock to broadcast from the option RS-232C port any event data at the time it is recorded.

Response: (Local) mm/dd/yyyy hh:mm:ss.ssssss nnnAL >
 (UTC) mm/dd/yyyy hh:mm:ss.ssssss nnnAU >

Where: nnn = Event-Buffer Read Index Number
 U = UTC Time
 L = Local Time

Broadcast Mode – STATUS

Command: **B4, O4**

B4 configures the clock to broadcast any status data from the main RS-232C port when it changes. O4 configures the clock to broadcast any status data from the option RS-232C port when it changes. NOTE: When a valid fault is detected, the specific status fault is broadcast once (with Julian day, and time) to the chosen serial port. When the fault clears, another message is sent describing the cleared fault.

Response: ddd:hh:mm:ss I=nn:nn X=nn:nn > (Updates whenever the status changes.)

Where: I, Internal clock conditions
 X, External clock conditions
 nn:nn, Status byte(Hex).

The 2 digits preceding the colon describe the present condition of the instrument. The 2 digits after the colon indicate the parameters, which have changed.

| Bit | Weight | Fault | Bit | Weight | Fault |
|-----|--------|---------------------------|-----|--------|----------------------------|
| 0 | 1 | OCXO Not Inst. (set to 1) | 4 | 16 | Out-of-Lock |
| 1 | 2 | Reserved (set to 0) | 5 | 32 | Time Error |
| 2 | 4 | Power Supply Error | 6 | 64 | OCXO Error (out of bounds) |
| 3 | 8 | IRIG Bus Fault | 7 | 128 | Receiver Failure |

Table 9.1: Fault Indications and Definitions

Broadcast Mode – EXT. ASCIICommand: **B5, O5**

B5 configures the clock to broadcast from the main RS-232C port, the time-of-day as ASCII data using an extended format prefaced with a time quality indicator (Q). O5 configures the clock to broadcast the same data from the option RS-232C port. The start bit of a carriage-return is transmitted on time. EXT. ASCII (or Extended ASCII) and adds a time quality indicator to the end of the Standard ASCII time string.

Response: >
 Q_yy_ddd_hh:mm:ss.000_--

Format: Q = Time quality indicator, and may be represented by:
 _ = (a space, ASCII 32) meaning it is locked with maximum accuracy.
 ? = (ASCII 63) unlocked, accuracy not guaranteed
 -- = (underline) graphically represents the location of an ASCII space
 and is used for clarity only.

Broadcast Mode – ASCII plus QUALCommand: **B6, O6**

B6 configures the clock to broadcast from the main RS-232C port the time-of-day as ASCII data appended with a time quality indicator. O6 configures the clock to broadcast the same data from the option RS-232C port. ASCII plus QUAL means Standard ASCII plus Time Quality Indicator.

Response: <soh>yyyy:ddd:hh:mm:ssQ >

Format: soh = Hex 01 – the start bit of the soh character is transmitted on time.
 Q = Time quality indicator. may be represented by:
 _ = (a space, ASCII 32) locked, maximum accuracy
 . = (ASCII 46) Error < 1 microsecond
 * = (ASCII 42) Error < 10 microseconds
 # = (ASCII 35) Error < 100 microseconds
 ? = (ASCII 63) Error > 100 microseconds

Broadcast Mode – YEAR plus ASCII

Command: **B8, O8**

B8 configures the clock to broadcast from the main RS-232C port, the year and time-of-day as ASCII data appended with a time quality indicator. O8 configures the clock to broadcast from the option RS-232C port. YEAR plus ASCII is the same as ASCII plus Time Quality Indicator adding the four digit year to the beginning of the string.

Response: <soh>yyyy:ddd:hh:mm:ssQ >

Format: soh = Hex 01 – the start bit of the soh character is transmitted on time.
 Q = Time quality indicator. may be represented by:
 - = (a space, ASCII 32) locked, maximum accuracy
 . = (ASCII 46) Error < 1 microsecond
 * = (ASCII 42) Error < 10 microseconds
 # = (ASCII 35) Error < 100 microseconds
 ? = (ASCII 63) Error > 100 microseconds

Broadcast Mode - NMEA183GLL

Command: **0,nB**

0,nB configures the clock to broadcast the National Marine Electronics Association Standard (NMEA - 0183) to broadcast from the main RS-232C port, where n = the update rate in seconds, from 1 to 9999.

GLL - Geographic Position, Latitude-Longitude

Latitude and Longitude of present vessel position, time of position fix and status.

Response: \$-GLL,llll.ll,a,yyyyy.yy,a,hhmmss.ss,A >

Where: GLL = Geographic Position, Latitude / Longitude
 llll.ll = Latitude of position
 a = N or S
 yyyyyy.yy = Longitude of position
 a = E or W
 hhmmss.ss in UTC
 A = status: A = valid data

Broadcast Mode - NMEA183ZDA

Command: **1,nB**

1,nB configures the clock to broadcast the National Marine Electronics Association Standard (NMEA - 0183) to broadcast ZDA format from the main RS-232C port, where n = the update rate in seconds from 1 to 9999. ZDA, time and date, includes the UTC day, month, year, and local time zone.

Response: \$-ZDA,hhmmss.ss,dd,mm,yyyy,xx,xx >

Where: ZDA = Time and date
 hhmmss.ss = Time in UTC
 dd = Day, 01 to 31
 mm = Month, 01 to 12
 yyyy = Year
 xx.xx = Local zone description, 00 to +/- 13 hours and minutes

9.2.2 Event Mode Commands

Return Specific Event

Command: **nnnA**

nnnA sets the event buffer read index to a specific event number (0 to 499), and returns that event information in either Local or UTC time format depending on how the command, nTA is configured.

Response: LCL mm/dd/yyyy hh:mm:ss.ssssss nnnL >
 or
 UTC mm/dd/yyyy hh:mm:ss.ssssss nnnU >

Format: nnn= Event-Buffer Read Index Number
 U = UTC Time
 L = Local Time

Set Event Channel Time

Command: **nTA**

nTA sets the time source as either Local or UTC, where n = 0 sets the event time to UTC and n = 1 sets the event time to Local.

Response: >

Set Channel – Deviation

Command: **AD**

AD sets channel A to the 1-PPS deviation mode.

Response: >

Set Channel – Event

Command: **AE**

AE sets Channel A to the event recording mode.

Response: >

Clear Event Buffer

Command: **CA**

CA clears the channel A event buffer and then resets the read and wrote indices to 0.

Response: >

Return Deviation for Event Channel

Command: **DA**

DA returns 1-PPS deviation and sigma for the event input.

Response: dddd.dd ssss.ss > (Results are in microseconds)

Format: dddd.dd = the deviation from 1 PPS (GPS), averaged over 16 samples
 ssss.ss = the standard deviation (sigma) of samples

Arm Event Trigger

Command: **AR**

AR arms the RS-232C event capture circuitry.

Response: >

Return Single Event

Command: **EA**

EA returns a single event record from the channel A event buffer. The record number ('nnn') increments once for every issuance of this command.

Response: Local Time mm/dd/yyyy hh:mm:ss.ssssss nnAL >
 UTC time mm/dd/yyyy hh:mm:ss.ssssss nnnAU >

Format: A = Channel A
 U = UTC time, Channel A
 L = Local time, Channel A
 NO DATA > (if buffer is empty)

9.2.3 Status Mode Commands

Return Status of Event/Deviation

Command: **SA**

SA returns the event/deviation channel setup information, read index number and write index number.

Response: D(E), R = nnn, S = mmm >

Format: D indicates the input channel is in 1-PPS deviation mode
 E indicates the input channel is in event mode
 nnn = Channel read index (000 to 499)
 mmm = Channel write index (000 to 499)

NOTE: When nnn = mmm, using the EA command to read event data, the event buffer is empty, i.e., all event data which has been recorded has also been read.

Return Clock Status

Command: **SC**

SC returns the current clock status.

Response: L/U, U=xx, S=nn >

Format: L = Clock currently locked to GPS (U for unlocked).
 xx = Indicates loss of lock period, up to 99 minutes.
 nn = User specified out-of-lock delay, 00 to 99 minutes (refer to Table A-8).
 S = Off if the out-of-lock function is deactivated, S = ZDL indicates zero delay.

Return DCXO Status

Command: **SD**

SD returns the DCXO (Digitally Compensated Crystal Oscillator) status.

Response: $\pm tt.t^{\circ}C \pm pp.pp$ PPM >

Format: tt.t = Ambient temperature in degrees C – Not used on these models
 pp.pp = Residual, corrected DCXO error, in parts per million

EEPROM Status

Command: **SE**

SE returns the EEPROM status.

Response: T=t CE=ee

Format: t = 0, No Timeout Error; t = 1, Timeout Error
 ee = Number of corrected errors in reading EEPROM data

Receiver Status

Command: **SR**

SR returns the current receiver status.

Response: V=vv S=ss T=t P=Off E=0 >

Format: vv = number of satellites, visible to the antenna, per almanac.
 ss = relative signal strength (range: 0 to 255, nominal value = 15)
 t = number of satellites being actively tracked (up to twelve)
 P = Off, indicates that the time dilution of precision (TDOP) calculation is not being performed. Returns 1.0 99.0, depending on satellite geometry, when TDOP calculation is being performed. A TDOP calculation is NOT performed if less than 3 satellites are visible, OR if Position-Hold is active. E = 0, currently unused.

Survey Status

Command: **SQ**

SQ returns Auto-Survey mode data. For a survey in progress, it returns current status of the survey. For a completed survey, it returns the final results of the survey, i.e. the averaged position.

Response: Sn Pm Fnnnn #nnnn Tyyyy:dd:hh:mm:ss Eddd:mm:ss.sss Ndd:mm:ss.sss Hmmmmm.mm >

Format: Sn = status of the Auto-Survey mode
 Pm = status of the Position-Hold mode
 Fnnnn = current number of fixes
 #nnnn = total number of fixes required
 yyyy:ddd:hh:mm:ss = completion time of the most recent average
 Eddd:mm:ss.sss = surveyed longitude
 Ndd:mm:ss.sss = surveyed latitude
 Hmmmmm.mm = surveyed elevation

Table 9.2 columns on the left show the significant three bits of the Auto Survey status byte, weighting and assignments. On the right, columns show the significant three bits of the Position Hold status byte, weighting and assignments.

| Bit | Weight | Function | Bit | Weight | Function |
|---------|--------|--------------------|---------|--------|-----------------------|
| 0 (LSB) | 1 | Single Auto Survey | 0 (LSB) | 1 | Position Hold Enabled |
| 1 | 2 | Power-On Survey | 1 | 2 | Position Hold Active |
| 2 | 4 | Suspend Survey | 2 | 4 | Position Hold ID:* |
| 3-7 | N/A | – | 3-7 | N/A | – |

Table 9.2: Survey (Sn) / Position-Hold Status (Pm)

*0=surveyed, 1=User-entered

System Status

Command: **SS**

SS returns the instrument operation status whenever the status changes. See Table 9.1 for bit assignments of clock conditions.

Response: I=nn:nn X=nn:nn >

Format: I internal clock conditions
 X external clock conditions
 nn:nn hexadecimal representations of the status byte.

The two digits preceding the colon describe present condition of the instrument. The two digits after the colon indicate the parameters that have changed. See Table 9.3

| Bit | Weight | Function | Bit | Weight | Function |
|---------|--------|---------------------------|-----|--------|------------------|
| 0 (LSB) | 1 | OCXO Not Inst. (Set to 1) | 4 | 16 | Out of Lock |
| 1 | 2 | Reserved (Set to 0) | 5 | 32 | Time Error |
| 2 | 4 | Power Supply Error | 6 | 64 | VCXO Tune Error* |
| 3 | 8 | IRIG-B Bus Fault | 7 | 128 | Receiver Failure |

Table 9.3: System Status Information Chart

Time Quality

Command: **TQ**

TQ returns a single ASCII character (0, 4–9, A, B, F) indicating estimated worst-case time quality, which follows the IEEE Standard, 1344. Table 9.4 gives the returned value and error category.

| Value | Error | Value | Error |
|-------|-----------------------|-------|----------------------------|
| 0 | Locked, max. Accuracy | 8 | Unlocked, accuracy < 10 ms |
| 4 | Unlocked, < 1 us | 9 | Unlocked, < 100 ms |
| 5 | Unlocked, < 10 us | A | Unlocked, < 1 s |
| 6 | Unlocked, < 100 us | B | Unlocked, < 10 s |
| 7 | Unlocked, < 1 ms | F | Clock failure |

Table 9.4: Unlocked Time Quality

The remainder of the information is the running position average, including all fixes since the beginning of the Auto Survey cycle. Gives latitude and longitude in degrees, minutes and seconds. Indicates E, W, N, and S respectively as East or West longitude and North or South latitude, and H indicating elevation in meters WGS-84 (World Geodetic Survey, 1984).

9.2.4 Local / Daylight Savings Time Setup Commands

Return Daylight Saving/Summer Time Settings

Command: **0DT**

0DT returns the current Daylight Saving / Summer Time Settings to the connected RS-232C port (Modes: OFF, ON, or AUTO).

Response: Mode :AUTO >
 START:02:00 Second SUN of MAR >
 STOP :02:00 First SUN of NOV >

Set Daylight Saving/Summer Time Mode

Command: **1,mDT**

1,mDT activates the Daylight Saving mode, where m = 0, 1, 2, with 0 = OFF, 1 = ON, and 2 = AUTO. When OFF this time adjust feature does not add the specified offset to local time display and output. With m = 1 (ON), the Daylight Saving / Summertime feature is always on. With m = 2, the Daylight Saving / Summertime feature will automatically change at the specified dates and times. To complete the Daylight Saving / Summer Time setup, you must also use the “Set Daylight Saving Auto Start” and “Stop” commands that follow below.

Response: >

Set Daylight Saving/Summer Auto Start Time

Command: **2,w,x,y,zDT**

2,w,x,y,zDT sets the starting (Start) date and time for Daylight Saving / Summer Time AUTO setting.

Where: w = Month (0 through 11), with 0 = Jan, 1 = Feb, ... 11 = Dec.
 x = WeekOfMonth (0 through 5), with 0 = First, 1 = Second, 2, = Third,
 3 = Last, 4 = Second from Last, and 5 = Third from Last.
 y = DayOfWeek (0 through 6), with 0 = Sun, 1 = Mon, ..., 6 = Sat.
 z = Minutes after midnight z (0 through 1440).

Response: >

Set Daylight Saving/Summer Auto Stop Time

Command: **3,w,x,y,zDT**

3,w,x,y,zDT sets the ending (Stop) date and time for Daylight Saving / Summer Time AUTO setting.

Where: w = Month (0 through 11), with 0 = Jan, 1 = Feb, ... 11 = Dec.
 x = WeekOfMonth (0 through 5), with 0 = First, 1 = Second, 2, = Third,

3 = Last, 4 = Second from Last, and 5 = Third from Last.
y = DayOfWeek (0 through 6), with 0 = Sun, 1 = Mon, . . . , 6 = Sat.
z = Minutes after midnight z (0 through 1440).

Response: >

Local Offset Command

Command: \pm hh:[mm]L

\pm hh:[mm]L sets the local offset in hours and fifteen-minute increments from -12:00 to +12:00, where 'hh' and 'mm' equal the number of hours and minutes, positive (East) or negative (West).

Response: >

9.2.5 Front Panel Control Commands

Disable Control Panel

Command: **FB**

FB disables all control-panel keys and blanks the front panel display – Model 1084B/C only.

Response: >

Enable Control Panel

Command: **FE**

FE enables all control-panel keys and activates the front panel display – Model 1084B/C only.

Response: >

Lock Setup Keys

Command: **FL**

FL disables setup control keys and activates the front panel display – Model 1084B/C only.

Response: >

Set Backlight – OFF

Command: **L0**

L0 disables the backlight operation – Model 1084B/C only, with Option 01 installed.

Response: >

Set Backlight – ON

Command: **L1**

L1 selects the continuous backlight operation – Model 1084B/C only, with Option 01 installed.

Response: >

Set Backlight – AUTO

Command: **L2**

L2 enables the automatic backlight operation – Model 1084B/C only, with Option 01 installed. It keeps the backlight active for 30 seconds after any key is pressed.

Response: >

9.2.6 IRIG-B Data Output Commands**IRIG Data – IEEE 1344**

Command: **In**

In activates (n=1) or deactivates (n=0) the IEEE 1344 extension, which uses IRIG-B control bits for additional information. Information includes the two-digit year, local offset, time quality and notification of pending non-sequence events such as leap seconds and daylight saving time changeovers. For additional information, see Section 7.3.4.

Response: >

IRIG Data – Local

Command: **IL**

IL configures all IRIG time data outputs to local time code reference.

Response: >

IRIG Data – UTC

Command: **IU**

IU configures all IRIG time data outputs to UTC time code reference.

Response: >

9.2.7 Position Data Commands

Set Position Hold – Elevation

Command: **MMMMM.mmH**

MMMMM.mmH command sets the antenna elevation in meters MSL (mean sea level); fractional meters of elevation are optional.

Response: \rhd

Format: **MMMMM.mmH**
 M = meters
 m = fractional meters

Set Position Hold – Latitude

Command: **dd:mm:ss.sssN(S)**

dd:mm:ss.sssN(S) sets antenna latitude (in Position-Hold Mode) in degrees, minutes and seconds, North or South. Position Hold must be enabled to set position.

Response: \rhd

Format: **dd** = degrees
mm = minutes
ss.sss = seconds (fractional seconds, optional)
N = North (S for South)

Set Position Hold – Longitude

Command: **ddd:mm:ss.sssE(W)**

ddd:mm:ss.sssE(W) sets antenna longitude (in Position-Hold Mode) in degrees, minutes and seconds, East or West. Position Hold must be enabled to set position.

Response: \rhd

Format: **ddd** = degrees
mm = minutes
ss.sss = seconds (fractional seconds, optional)
E = East (W for West)

Return Elevation

Command: **LH**

LH returns the current antenna elevation. In Position Hold mode, 'LH' returns the current position-hold elevation setting. In Fix mode, LH returns the most recent computed elevation value (calculated each second). Elevation is referenced to the WGS-84 datum.

Response: nnnnn.nn > (from -1000.00 to +18000.00 meters WGS-84)

Return Latitude

Command: **LA**

LA returns the current antenna latitude. In Position Hold mode, LA returns the current position-hold latitude setting. In Fix mode, LA returns the most recent computed latitude value (calculated each second).

Response: Ndd:mm:ss.sss >

Format: N = North (S for South)
 dd = degrees
 mm = minutes
 ss.sss = seconds (fractional seconds)

Return Longitude

Command: **LO**

LO returns the current antenna longitude. In Position Hold mode, LO returns the current position-hold longitude setting. In Fix mode, LO returns the most recent computed longitude value (calculated each second).

Response: Wddd:mm:ss.sss >

Format: W = West (E for East)
 ddd = degrees
 mm = minutes
 ss.sss = seconds (fractional seconds)

Position-Hold – OFF

Command: **PH0**

PH0 deactivates the Position-Hold timing mode. The receiver resumes computing time and position solutions approximately each second. This is referred to as the Fix mode.

Response: >

Position-Hold – ON

Command: **PH1**

PH1 activates the Position-Hold timing mode. In this mode, the receiver position is held fixed and each channel is used to compute a timing solution. These solutions are averaged together, resulting in reduced timing noise due to Selective Availability and RF channel noise. To operate

properly, the position used by the receiver must be fairly accurate. Due to the risk that previously stored position data may be inaccurate, exercise caution when activating the Position–Hold mode without either performing an Auto Survey or getting the position directly. Failure to observe these precautions may result in serious timing errors.

Response: \rhd

9.2.8 Survey Mode Commands

Auto Survey Mode Selection

Command: **m:nQ**

m:nQ sets the mode (m) and number of fixes to average (n). Used to automatically determine position data for Position–Hold. Requires Position–Hold mode to be ON to start the survey. See conditions in Table 9.5. Use the SQ command during a survey to obtain the survey status. Activate the Position–Hold mode with the PH1 command.

Response: \rhd

| m | Condition | n | Condition |
|----------|---------------------------------|----------|------------------------|
| 0 | Survey Off | 3 | 900 fixes (15 min.) |
| 1 | Initiate single auto survey | 4 | 1800 fixes (30 min.) |
| 2 | Perform auto survey at power on | 5 | 3600 fixes (1 hour) |
| 3 | Temporarily suspend auto survey | 6 | 7200 fixes (2 hours) |
| 4 | Resume suspended auto survey | 7 | 14400 fixes (4 hours) |
| n | Condition | 8 | 28800 fixes (8 hours) |
| 0 | Single position fix | 9 | 43200 fixes (12 hours) |
| 1 | 60 fixes (1 min.) | 10 | 86400 fixes (24 hours) |
| 2 | 300 fixes (5 min.) | – | – |

Table 9.5: Auto Survey Setup Conditions

9.2.9 Date and Time Commands

Set Receiver Time

Command: **yyyy:mm:dd:hh:mmTS**

TS sets the receiver time to the entered value (UTC format), *only when not locked to the GPS*. The command is ignored when locked to satellites. When the receiver is initially activated, and has not locked onto satellites, acquisition time may be improved by giving the clock an initial estimate of UTC time, which it can use (with stored position and almanac data) to determine which satellites and Doppler shifts to use in acquisition.

Response: \triangleright

Format: yyyy = year
 mm = month
 dd = day
 hh = hour
 mm = minute

Return Local Date

Command: **DL**

DL returns the current date, in the Local time zone.

Response: ddmmyyyy \triangleright

Return UTC Date

Command: **DU**

DU returns the current date, in the UTC time zone.

Response: ddmmyyyy \triangleright

Return Local Time

Command: **TL**

TL returns the current Local time.

Response: ddd:hh:mm:ss \triangleright

Return UTC Time

Command: **TU**

TU returns current UTC time.

Response: ddd:hh:mm:ss \triangleright

NOTE: The DL, DU, TL and TU command formats are identified as follows:

yyyy = year
 hh = hour
 mmm = month (JAN DEC)
 mm = minute
 dd = day of month
 ss = second
 ddd = day of year

9.2.10 Programmable Pulse Output Commands

Pulse Width

Command: **nnn.nnPW**

nnn.nnPW configures the Programmable Pulse output pulse width in seconds, from 0.01 to 600 seconds, in Seconds per Pulse, Pulse per Hour and Pulse per Day modes.

Response: \rhd

Format: nnn.nn (0.01 to 600 seconds in 10-millisecond increments).

For values greater than 1, use a decimal point and enter trailing zeros as applicable.

Examples:

1 = 0.01 second
 10 = 0.10 second
 1.00 = 1 second
 100 = 1 second

Seconds Per Pulse / Pulse Per Hour

Command: **m,nPS**

m,nPS configures the programmable pulse as “Seconds per Pulse” or “Pulse Per Hour” mode as follows:

Response: \rhd

Format: m = 0, seconds-per-pulse mode
 m = 1, pulse-per-hour mode
 n = 1 – 60000 seconds if seconds-per-pulse mode
 n = 1 – 3599 seconds offset from hour if pulse-per-hour mode

For the Seconds-Per-Pulse mode, the first pulse will be on time at the top of the minute. If n is divisible by 60, the first pulse will be on time at the top of the hour.

For the Pulse-Per-Hour mode, the pulse will be on time at the second after the hour described by n. For example, 1,1200ps would cause a pulse at exactly 20 minutes after the hour.

If only one number is present then the number sets the seconds as in seconds-per-pulse mode.

Set Alarm Time Mark

Command: **ddd:hh:mm:ss(.ss)OU(OL)**

OU sets the time at which the clock issues the programmable pulse, in the UTC format. OL sets the time at which the clock issues the programmable pulse, in the Local format. If ddd is set to 0, the pulse will repeat daily at the specified time. If ddd is set from 001 to 366, the output pulse will be generated at the next occurrence of the specified time and date.

Response: >

Format: ddd = day of year (1 through 366)
hh = hour (0 through 23)
mm = minute (0 through 59)
ss = second (0 through 59)
(.ss) = fractional seconds in 0.01 increments (00 through 99)
OU = UTC time (OL for Local time)

Set Pulse Output to Slow Code

Command: **nCM**

nCM configures the pulse output to slow code. Slow Code pulse output is held high and goes low for six seconds on the day, four seconds on the hour and two seconds on the minute.

Response: >

Format: n = 0, Slow Code off
n = 1, UTC Slow Code
n = 2, Local Slow Code

Set Pulse Polarity

Command: **nPP**

nPP sets the programmable pulse output polarity (i.e. TTL/CMOS high or low), where n = 0 sets pulse polarity to positive, and n = 1 sets the pulse polarity to negative. Positive means that the output voltage is held low until the beginning of the pulse period, at which time it transitions high. Negative means that the output voltage is held high until the beginning of the pulse period, at which time it transitions low.

Response: >

9.2.11 Antenna System Delay Commands

Set Antenna Delay

Command: **nnnnnnDA**

nnnnnnDA sets antenna system delay compensation value. NOTE: Factory default setting for the standard 15-meter (50-foot) cable is 60 ns. Time range is from 0 to 999999 nanoseconds. The exact syntax for a 60-ns delay is 60DA. See Section 4.4.1 for information on calculating cable delay.

Response: >

Set Clock Offset

Command: **nnnnnnnnnDS**

nnnnnnnnnDS sets internal system delay compensation value. This includes the remote receiver cable delay. It is also used to advance the output pulse by an arbitrary offset of zero up to one millisecond, from actual time.

Response: >

9.2.12 Out-of-Lock Commands

Set Out-of-Lock Time

Command: **(-)nnK**

(-)nnK configures the amount of delay time (in minutes) following loss of satellite synchronization before an out-of-lock signal is generated and output via rear panel connector. A negative number turns the out-of-lock function OFF. n = 0 sets the out-of-lock time to zero delay. n = 1 to 99 sets the amount of delay time (in minutes).

Response: >

9.2.13 Miscellaneous Commands

Return Firmware Version

Command: **V**

V returns the firmware version date of the installed ROM.

Response: dd mmm yyyy >

Return Display Buffer

Command: **Z**

Z returns the contents of Display Buffer.

Response: Echoes current display (40 characters); no line wrap. For display contents, see Chapter 10, Startup and Basic Operation.

Set Option Control

Command: **m,n,k,lXI**

m,n,k,lXI configures the specified option in the clock, where m = 0 for the main board and m = 1 for the auxiliary board. See Table 9.6.

Where:

m = 0 for Main board option, and m = 1 for Aux board option.

n = option number (see table below)

k = security key; 1084

l = *use only if n specifies Option 28*. l = 0 for 60 Hz and l = 1 for 50 Hz.

Response: ↳

| Main board, n = | Option Number |
|-----------------|---------------|
| 0 | NONE |
| 1 | 18A |
| 2 | 19 |
| Aux board, n = | Option Number |
| 0 | NONE |
| 1 | 03 |
| 2 | 06 |
| 3 | 17 |
| 4 | 20A |
| 5 | 23 |
| 6 | 27 |
| 7 | 28 |
| 8 | 29 |
| 9 | 32 |

Table 9.6: Option Control Settings

Option Control Examples

1. **Model 1084A, Main board Opt. 19, Aux board Opt. 28**
0,1,1084XI
1,4,1084,0XI

Note: the 0 before XI in the last command sets the Option 28 frequency to 60 Hz.

2. **Model 1084A, Main board Opt. none, Aux board Opt. 32**
1,6,1084XI

9.3 Communication Port Information

Table 9.7 gives a list of functions and associated pins for both the RS-232C and RS-485 ports.

| Pin No. | Function | Pin No. | Function |
|----------------|---------------------------|----------------|------------------|
| 1 | Not Connected | 6 | RS-232C Input |
| 2 | RS-232, Rx Data | 7 | Not Connected |
| 3 | RS-232, Tx Data | 8 | RS-422/485, Tx-A |
| 4 | RS-232C Output/Prog Pulse | 9 | RS-422/485, Tx-B |
| 5 | Ground | – | – |

Table 9.7: Main RS-232C Port Pin Definitions

NOTE: pins 6 – 9 are not connected on the optional RS-232C port.

Chapter 10

Startup and Basic Operation

10.1 Initial Startup Sequence

Before powering ON any of these clock models, make sure that the chassis cover is installed and if equipped with a power switch, that inlet power is properly connected to the power inlet connector. If the clock does not have a power switch, then the clock will begin the Startup Sequence when inlet power is connected to the rear panel. When the clock starts, several things should things should happen¹ in the sequence listed below:

- The four annunciator LED's initially should flash momentarily, then the OPERATE, ON LINE and UNLOCKED LED should light steadily.
- The LCD should display several introductory messages - see below (for 1084B/C clocks only).
- The Out-of-Lock Relay will be in the out-of-lock position and the FAULT relay should switch to the OK (no fault) position.
- Eventually, the UNLOCKED LED should extinguish.
- The Out-of-Lock Relay should change to Locked (non-faulted) position after a few minutes.
- The LCD should indicate that the clock is Locked (for 1084B/C clocks).

10.1.1 Clock Time, Startup Mode – 1084B/C

When the clock first starts, it will not indicate the correct time until it is locked to the GPS. Pressing the TIME key before the UNLOCKED LED is extinguished will produce the message:

TIME NOT AVAILABLE

For IRIG-B time, it will begin counting from zero, with the Julian Day also set to zero. This method was chosen so that there would be no mistake in interpreting that the clock was in startup mode. For example, the time could indicate as follows:

¹Startup behavior is based on Models 1084B/C clocks with a display. Startup behavior for the 1084A have no visible display other than four annunciator LEDs. For the 1084A, time and position (and other) data may be viewed if monitoring through a RS-232 port.

```

000:00:00:01
000:00:00:02
000:00:00:03
.
265:13:45:21
265:13:45:21 (these values chosen for illustrative purposes only)

```

During a short period of time (from a few minutes to a few seconds) the displayed clock time may jump and add or lose some seconds as more satellites are acquired. This is normal, until the full set of ephemeris data is received by the GPS receiver from the GPS (satellites), when the time will be accurate. At this time, the Out-of-Lock LED should extinguish and the Out-of-Lock relay close.

10.2 Front Panel Indication – 1084B/C

10.2.1 Display Indication at Startup

In the startup sequence, the LCD display should indicate clock status as follows:

```

ARBITER SYSTEMS GPS
SUBSTATION CLOCK
followed by:
COPYRIGHT (C) 2006
ARBITER SYSTEMS, INC.
followed by:
CLOCK STATUS
STARTUP
followed by:
CLOCK STATUS
UNLOCKED – MIN
followed by:
CLOCK STATUS
NOT STABILIZED

```

After this, the second line of the status display should change to UNLOCKED, or LOCKED depending on the previous operation, inactivity or if the clock has been moved. During startup, the Unlocked LED should extinguish after the GPS receiver begins tracking satellites.

10.2.2 Other Display Indications When Unlocked

| | |
|------------------|----------------------------------|
| Time Display | TIME NOT AVAILABLE |
| Position Display | POSITION NOT AVAILABLE |
| Event Display | PLEASE WAIT! TIME ADJUSTMENTS |
| Status Display | GPS RECEIVER STATUS |

TRACKING: 00

10.2.3 Status Display Indications

There are three indications when successively pressing the STATUS key. These are as follows:

CLOCK STATUS
STARTUP*

*The second line will change between STARTUP, to UNLOCKED (with time), to NOT STABILIZED, to LOCKED–AUTO SURVEY, to LOCKED–POSITION HOLD. followed by:

GPS RECEIVER STATUS
TRACKING: 00*

*The number of tracked satellites can change from 0 to 12.

followed by:

DCXO STATUS
DEVIATION: $\pm nn.nn$ PPM

followed by:

EEPROM STATUS
CORR. ERRORS = 0

If the number of corrected (CORR.) errors begins to climb, contact the factory about replacing the EEPROM.

10.2.4 Event/Deviation Display

There are separate displays when pressing the EVENT/DEVIATION key, depending on the setting. Successive events appear when repeatedly pressing the EVENT/DEVIATION key, or if configured for DEVIATION, it will indicate the 1-PPS Deviation (updates once per second) and Sigma. If there are no records, the second line will indicate "NO DATA".

Event Display

Ch A EVENT nnn
ddd:hh:ss.ssssss

Where:

nnn = event number(000 to 499)
ddd = day of year of the event(1 to 366)
hh = hour of the event(00 to 23)
mm = minute of the event(00 to 59)
ss.ssssss = second and fractional seconds of the event

Deviation Display

1 PPS: 0.00 μ S
SIGMA: 0.00 μ S

10.2.5 IRIG-B Time Data

IRIG-B time is immediately sent out, when the clock is powered ON, from any timing output port configured for IRIG-B as indicated above. Time will not be accurate until the Unlocked LED extinguishes.

10.3 Clock Status Display Mode

When first applying power to the clock, the display will indicate several startup messages, then will revert to Clock Status mode condition called STARTUP. After a short time, while the GPS receiver begins collecting data from the GPS, it will indicate either UNLOCKED (XX Min), NOT STABILIZED, LOCKED–AUTO SURVEY, or LOCKED–POSITION HOLD. There are several faults that are indicated, if they exist, and are as follows:

| Bit | Weight | Function |
|-----|--------|-------------------------------|
| 0 | 1 | OCXO Not Installed (set to 1) |
| 1 | 2 | Reserved (set to 0) |
| 2 | 4 | Power Supply Error |
| 3 | 8 | IRIG BUS Fault (was Opt. 18) |
| 4 | 16 | Out of Lock |
| 5 | 32 | Time Error |
| 6 | 64 | VCXO Error (out of bounds) |
| 7 | 128 | Receiver Failure |

Table 10.1: Fault Conditions

For additional information on internal faults, please see Chapter 2, Front and Rear Panels, and Chapter 9, Serial Communications and Command Set, status commands, page 68.

10.4 Time Display Modes – 1084B/C

After establishing GPS satellite synchronization, date and time information can be displayed on the front panel by pressing the TIME key and scrolling through the four available displays. Press this key to select the time display mode (UTC or Local) time data (Date/Time or Day of Year).

10.4.1 Date and Time Display, Universal Time Coordinated (UTC)

The Date and Time Display UTC mode displays UTC, in the Date and Time format, as maintained by the United States Naval Observatory (USNO), as described below:

```
UTC DATE/TIME www
dd mmm yyyy hh:mm:ss
```

Where:

www = day of the week (Mon - Sun)
 dd = day of the month
 mmm = month (Jan - Dec)
 yyyy = the year
 hh = the hour (00 - 23)
 mm = the minute (00 - 59)
 ss = the second (00 - 59)

This mode displays UTC, Time of Year mode, without the application of daylight saving correction and local offset.

10.4.2 Time of Year Display, UTC

The Time of Year Display mode also displays UTC, in Time of Year format, which differs from the previous format as follows:

UTC DATE/TIME www
 yyyy ddd:hh:mm:ss

Where:

ddd = day of the year (001 - 366)

This mode displays UTC, Time of Year mode, without the application of daylight saving correction and local offset. NOTE: Daylight saving and local offset have no effect on this display.

10.4.3 Date and Time Display, Local Time

The Date and Time Display mode displays the date and time after the daylight-saving correction and local offset have been applied, but in the same format as that of the Date and Time, UTC:

LOCAL DATE/TIME www
 dd mmm yyyy hh:mm:ss

10.4.4 Time of Year Display, Local Time

The Time of Year Display mode displays the time of year after the daylight-saving correction and local offset have been applied, but in the same format as that of the Time of Year, UTC:

LOCAL DATE/TIME www
 yyyy ddd:hh:mm:ss

NOTE: Unless the daylight saving and local offset parameters have been set properly, this display may not reflect the correct local time.

10.4.5 Daylight Saving–Summer Time

The Daylight Saving / Summer Time (DST) configuration feature allows expanded settings. The addition of AUTO allows the user to customize the DST/Summertime settings to match the requirements of locations in either Northern or Southern latitudes. For setup information through the front–panel interface, please see Section 6.3.1.

The DST/Summertime configuration can be changed through the serial port or through the front panel keypad. For setup information through the RS-232C port, please see Section 9.2.4.

10.5 Position Display Modes – 1084B/C

When the clock is first powered ON and acquiring satellites, the only position information available is the previous position, stored in the clocks setup EEPROM. This position information reflects the location of the receiver as determined by the last position while locked to at least four satellites. Displayed position will be based on the most recent position fix.

Press the POSITION key to access longitude, latitude, and elevation data values. Repeatedly pressing the POSITION key scrolls the readout display continuously through these values. If pressed prior to acquisition of enough satellites to accurately determine and update position data, these numbers will reflect the receiver’s power-on defaults.

Synchronization to a minimum of four satellites is necessary for precise determination of longitude, latitude, and elevation. When meeting this minimum satellite lock requirement, POSITION values will accurately correspond to the present antenna location.

10.5.1 Longitude Display

ANTENNA LONGITUDE
XXX° XX’ XX.XXX” W*

Where:

*W = WEST, or E = EAST

10.5.2 Latitude Display

ANTENNA LATITUDE
XX° XX’ XX.XXX” N*

Where:

*N = NORTH, or S = SOUTH

10.5.3 Elevation Display

ANTENNA ELEVATION
XXXXX.XX m WGS-84

Where the elevation is displayed referenced to the WGS-84 datum.

Appendix A

Technical Specifications and Operating Parameters

A.1 Scope

In this section you will find information relating to the functional and operational characteristics of the standard Model 1084A/B/C Satellite Controlled Clocks. Topics included in this section are Receiver Characteristics, I/O Configuration, System Interface(s), Antenna System, Operator Interface(s), and Physical Specifications.

NOTE: Specifications are subject to change without notice.

A.2 Receiver Characteristics

A.2.1 Input Signal

- GPS L1 C/A code, 1575.42 MHz.

A.2.2 Timing Accuracy

- GPS/UTC time ± 100 ns rms (at 1-PPS output), when receiving 4 or more satellites (one satellite if position is known within 25 meters) in the presence of Selective Availability (SA).
- < 40 ns, typical in Position-Hold mode

A.2.3 Internal Oscillator, Stability

- Standard: DCXO, 1×10^{-7}

A.2.4 Allen Variance (locked to GPS, in Position-Hold Mode)

- 1 second 5×10^{-10} (2×10^{-10} , typical)
- 1 day 5×10^{-13}

A.2.5 Position Accuracy (rms)

- 25 meters, SA (USA Department of Defense Selective Availability) OFF, 100 meters, SA ON.
- Elevation, 140 meters, SA on

A.2.6 Satellite Tracking

- 12 channels, C/A code (1575.42 MHz)

The receiver simultaneously tracks up to twelve satellites. Results from all tracked satellites are averaged in Position-Hold Mode or, with Position-Hold Off, are determined by least-squares estimation.

A.2.7 Acquisition

- less than 5 minutes current almanac
- less than 20 minutes without current almanac.
- greater than 20 minutes in areas where antenna has limited or obstructed view of the sky.

A.3 I/O Configuration

Output signals, or the designated input, may be selected on specified connector by means of internal push-on jumpers and special wiring. Each output connector is independently buffered.

A.3.1 I/O Connectors

I/O connectors may be configured to any one of the output signals or a specific input function as listed below:

- Signals, three BNC, with output signals as described below.
- Relays, two sets, 5-mm plug-type terminal block

A.3.2 Standard Output Signals

- IRIG-B: Modulated (1 kHz carrier). Analog outputs are complementary emitter follower (2N4401/4403) with 20-Ohm protective resistors, driven by a (LF442) op-amp. Modulated, bus driver, 4 V_{pp}, 20-Ohm source impedance, and drives a 50-Ohm load at 3 V_{pp} – one BNC connector
- User configurable: IRIG-B, Unmodulated or Programmable Pulse – one BNC connector
- User configurable: 1 PPS (10-ms pulse-width), IRIG-B Unmodulated (not available on earlier units) or IRIG-B Modified Manchester (IEEE Std 1344) – one BNC connector

User configurable outputs are 5-V CMOS bus drivers with 10-Ohm source impedance and ± 75 -mA drive capability.

A.3.3 Relay Contacts

- 2 sets, form-C (SPDT) fail safe, 0.3 A at 130 Vdc; one is set to Locked function; and the second one may be configured to Fault, 1 PPH, or Programmable Pulse – jumper-selectable.

A.3.4 Programmable Pulse Output

- Five Modes: (1) Seconds-per-pulse; repetitive pulse, every 1 – 60,000 seconds; (2) Pulse-per-hour: every 0 – 3599 seconds after the hour, (3) starting at the top of the hour; (4) Set Alarm Time Mark: daily at a specified time of day; or one-shot at a specified time of year, (5) Slow Code – UTC, LCL (+ or –). Pulse duration programmable 0.01 – 600 seconds, except in one-shot mode, where the output is Low prior to the specified time and High thereafter.

A.3.5 Event A Input

- Event A input provides one input as an alternate function, with a simple hardware modification to the 1-PPS configurable output. The input may be configured to accept an external 1-PPS signal, and measure the deviation from the 1-PPS/GPS signal with 100-ns resolution.
- Event A input allows configuration of each input to record up to 500 sequential events with 100-ns resolution, provided that the events are separated by 11 ms. Event data is stored in battery-backed RAM.

A.4 Antenna System

The included antenna is directly mounted in 19-mm (3/4-in.) hole. Other mounting configurations are available (contact Arbiter Systems).

- GPS Antenna Assembly, 3/4-in. Pipe Thread Mount, 35 dB gain; Operates on 5 Vdc.
- Optional Antenna Mounting Bracket available to mount on 60-mm (2-in. nominal) pipe (p/n AS0044600, see Figure 4.2).
- Magnet mount, lip mount, or post mount (30-mm max. diameter) available

A.4.1 Antenna Cable

- 15-meter (50-foot) cable included with antenna.
- Other cable styles and lengths available see Table 4.2.

A.5 Operator Interface

A.5.1 Setup Methods

- Via RS-232C Interface
- 8 Front-panel keys (Models 1084B/C Only)

| | | |
|------------------------|--------------------|----------------|
| Initial Position | System Delays | Position Hold |
| RS-232 Parameters | Programmable Pulse | Option Control |
| Local Hour | IRIG Time Data | – |
| Out-of-Lock Indication | Event/Deviation | – |
| Backlight | Auto Survey | – |

Table A.1: Setup Functions Listed

A.5.2 Setup Functions

A.5.3 Display

- 2-line by 20-character supertwist LCD; backlight available (Option 01)
- 9-character by 0.8-in. LED for day and time (UTC or Local) readout (Model 1084C only)
- Time: UTC or Local
- 1-PPS (input) Deviation
- Position: Latitude, Longitude and Elevation
- Event Time
- Status: clock, Receiver, EEPROM, and DCXO

A.5.4 Display Functions

- Time: UTC or Local
- 1 PPS (input) Deviation
- Position: Latitude, Longitude and Elevation
- Event Time
- Status: Clock, Receiver, DCXO & EEPROM
- Configuration (1084B/C)

A.5.5 Annunciators

- Operate (Green)
- On line (Green)
- Unlocked (Red)
- Fault (Red)

A.6 System Interface

A.6.1 RS-232C Interface

| Pin No. | Function | Pin No. | Function |
|---------|--------------------------|---------|------------------|
| 1 | Not Connected | 6 | RS-232 Input |
| 2 | RS-232, Rx Data | 7 | Not Connected |
| 3 | RS-232, Tx Data | 8 | RS-422/485, Tx-A |
| 4 | RS-232 Output/Prog Pulse | 9 | RS-422/485, Tx-B |
| 5 | Ground | – | – |

Table A.2: Main RS-232 Port Pin Definitions

NOTE: pins 6 – 9 are not connected on the optional RS-232 port. RS-422/485: Transmit only.

Communication Parameters

- Selectable, 300 – 19,200 baud, 7 or 8 data bits, 1 or 2 stop bits, odd/even/no parity
- Supports all keyboard functions

A.6.2 Data Formats

Supports continuous output data in the following formats:

| | |
|---------------------------------------|---------------------------------------|
| <SOH>ddd:hh:mm:ss<CRLF> | Broadcast Mode, ASCII |
| 44hhmmss<CRLF> 55ddd<CRLF><BEL> | Broadcast Mode, Vorne |
| mm/dd/yyyy hh:mm:ss.ssssss nnn <CRLF> | Broadcast Mode, Event |
| ddd:hh:mm:ss I=nn:nn X=nn:nn <CRLF> | Broadcast Mode, Status |
| <CRLF> Q yy ddd hh:mm:ss.000 (space) | Broadcast Mode, Extended ASCII |
| <SOH> ddd:hh:mm:ssQ <CRLF> | Broadcast Mode, ASCII w/Time Quality |
| <SOH> yyyy:ddd:hh:mm:ssQ <CRLF> | Broadcast, ASCII, year w/Time Quality |

For more information refer to RS-232 Broadcast Commands contained in Appendix A, Table A-1.

A.7 Physical Specifications

A.7.1 Dimensions

- **Instrument:** 430-mm W x 44-mm H x 280-mm D (16.9-in. x 1.7-in. x 11.0-in.)
- **Antenna:** 77-mm diameter x 66-mm height (3.05-in. x 2.61-in.)

A.7.2 Weight

- 2.0 kg (4.4 lbs.) net. (Instrument)
- 2.2 kg (4.84 lbs.) net. (Antenna and Cable)
- 0.5 kg (1.1 lbs.) net. (Option 06)
- 8 kg (18 lbs.) includes antenna, cables, and accessories. (Shipping)

A.7.3 Power Requirements

The Model 1084A/B/C comes with one of three user-specified internal power supplies. Additionally, the antenna receives power through the antenna cable connected to the Type F connector on the rear panel.

- Option 07: 85 – 264 Vac, 47 – 440 Hz, or 110 – 370 Vdc, < 20 W typical (Standard power supply)
- Option 08: 10 – 60 Vdc (DC only), < 20 W typical. Uses a three-position terminal strip in place of the IEC-320 power inlet module; includes Surge-Withstand Capability
- Option 10: 110 – 370 Vdc, < 20 VA or 85 – 264 Vac, 47 – 440 Hz, with three-position Terminal Power Strip and Surge-Withstand Capability

A.7.4 Power Connector

- Option 7, Standard Power Supply: This includes a fused IEC-320 power inlet module with mating ac cord. Plug type specified as Options P1 through P10 (see Section 3.2.1).
- Options 08 and 10: Using a 3-pole terminal strip power inlet with Surge-Withstand Capability (see Section 3.3 and 3.4).

A.7.5 Electro-Magnetic Interference (EMI)

- Conducted Emissions: power supply (Options 07 and 08) complies with FCC 20780, Class A and VDE 0871/6.78, Class A
- Surge Withstand Capability (SWC), power inlet (Options 08 and 10) designed to meet ANSI/IEEE C37.90-1 and IEC 801-4.

A.7.6 Temperature and Humidity

| Temperature | Operating | Storage |
|--------------------|--------------------------|--------------------------|
| Instrument | 0 to 50°C | -40 to 75°C |
| Antenna | -40 to 85°C | -55 to 100°C |
| Antenna Cable | -40 to 60°C | -40 to 80°C |
| Humidity | 10 to 90% non-condensing | 10 to 90% non-condensing |

Table A.3: Temperature and Humidity List

Appendix B

Using Surge Protectors

B.1 Introduction

¹Today's data equipment has become extremely vulnerable to a phenomenon known as voltage and electrical transients. A single IC package can contain over 100,000 memory bits and more than 5,000 logic gates. The high sensitivity due to the small size of the chips used in these packages makes them susceptible to quick degradation from voltage surges and transients. PLCs, MUXs, HUBs, RTUs, SCADA, and Telemetry equipment are especially vulnerable to electrical surges because of their low operation voltages. Many of these components can be damaged beyond repair by an electrical surge as low as 20 volts.

Sources of electrical surges are numerous. The most common is a nearby lightning strike, which will affect nearby data lines through induction. Industrial transients are also significant because they are man made disturbances caused by switching and commuting of electrical motors. The operation of such devices can cause abrupt shifts in the ground potential that can generate a current flow through a nearby data-line in order to equalize the ground potential.

Electrostatic discharge is another form of an electrical surge that can be included in this group. Although often overlooked, (ESD) can potentially be a very harmful transient to fragile data equipment. ESD occurs due to two non-conducting materials rubbing together, causing electrons to transfer from one material to another.

The consequences of electrical surges and transients may be severe. Although the life span of these electrical phenomena is very short, the amount of energy that is carried can be extremely high. A typical transient event can last from a few nanoseconds to several milliseconds carrying several thousand volts and at least a few hundred amps of current. These events may cause burnt-line cards, lockups, loss of memory, problems in retrieving data, altered data, garbling . . . etc.

B.2 Grounding

A protection system with a poor ground is the same as having no protection at all. Too many times proper grounding has been overlooked. Recommended grounds are the utility company ground, a ground rod, well casings, and cold water pipes that are of continuous metal. Caution! Sometimes the metal-cold water pipes are repaired and/or extended PVC piping. The introduction of PVC material renders the cold water pipe ground unacceptable. A thorough investigation of a cold water

pipe ground is important since the PVC repairs or extensions may be covered by drywall.

Grounds that are unacceptable include sprinkler pipes, PVC pipe, conduit, buried wire, and any ground that cannot be verified.

Bonding ensures the most effective ground. Bonding ties all of the grounds in the building together electrically. If there is a rise in ground potential and all of the grounds are bonded, no damage will occur since it is differential voltage that causes problems.

It is absolutely necessary to make sure that the ground used for the AC power is the same as the ground used for the data-line surge protectors. A common ground reference must be achieved for all equipment. All ground wires must be as short as possible and it is imperative that the ground wire not be coiled or looped. The ground wire must be as straight as possible; remember that it must be the path of least resistance. Regarding the diameter of the ground wire, the larger the better. The larger the diameter, the better electrical conductivity. Finally, the earth ground resistance on which the whole grounding system relies must be less than 5 ohms.

Lines that typically need protection include incoming central office trunks, lines to off-premise sites, local area networks and campus environments with multiple buildings. A good rule of thumb to remember is that all lines entering or exiting a building need protection. Both ends of the cables between buildings must be protected!

For additional technical details, please contact Citel, Inc. at www.citelprotection.com.

Notes

¹Citel, Inc. 1515 NW 167th Street, Miami, FL 33169, USA, (800) 248-3548,(305) 621-0022, www.citelprotection.com

Appendix C

Options List

C.1 Introduction

Each Arbiter Model 1084A/B/C Satellite-Controlled Clock has a number of standard options that may be installed for special purposes. This section is devoted to these options, and provides supplemental and detailed information for operation and configuration of these options. While many of these options apply to other clock models than the Model 1084A/B/C, references to these models will be found throughout this document.

Additionally, there will be references to certain capabilities and specifications that apply only to specific clock models when using these options. For example, with Option 03, there will be a large list of possible signals that can be selected with the option board jumpers. Some of these signals do not apply to the Model 1084A/B/C series clocks because the signals do not originate on the main clock board. The key to usage is to check the basic specification of the clock to determine the option capability.

C.2 Option 01: Backlighted LCD Display

C.2.1 General Description – 1084B/C Only

Option 01 for the Arbiter System line of Satellite-Controlled Clocks adds illumination to the front panel display, if so equipped. The standard reflective liquid crystal display (LCD) is replaced with a transfective LCD. An Electro-luminescent (EL) panel located behind the transfective LCD provides backlighting; thereby increasing the readability of the display in subdued lighting conditions. The backlight can be set to remain on indefinitely, or to turn off after a predetermined time following the last keystroke. With the backlight turned off, the display is still readable in ordinary ambient light.

C.2.2 Specifications

- **Initial Luminance:** 30 cd/m² minimum
- **Service Life:** 4000 hours (down to 10 cd/m²)

C.2.3 Configuration

The SETUP menu outlined in the Operation Manual contains a sub-menu, which allows selection of the backlight-operating mode. To set the backlight-operating mode, observe the following steps:

1. With the clock power turned on, press the SETUP key. The display should change to read, SET RS-232.
2. Press the SETUP key repeatedly, until the display reads, “SET BACK LIGHT?”. Press the ENTER key to select the backlight sub-menu. The current backlight operating mode will be displayed, from one of the following selections:
 - OFF – Backlight never on.
 - ON – Backlight always on.
 - AUTO – Backlight turns on when a key is pressed, remains on for 30 seconds after the last key is pressed. This is the preferred mode for applications requiring a lighted display, since it will provide the longest EL panel lifespan (see Specifications, above).
3. Pressing the UP and DOWN keys will change the selection. When the desired operating mode is displayed, press the ENTER key to confirm the choice and return to the first level of the SETUP menu.

The backlight operating mode can also be changed via the RS-232C port, using the L0, L1, or L2 commands for OFF, ON, and AUTO, respectively. For details regarding this and other capabilities of the RS-232C port, refer to Appendix A, page 78.

C.3 Option 02: GPS Battery Backup - *Obsolete*

NOTE: This option has become obsolete because the new GPS receivers incorporate a lithium dioxide data backup battery. See the Model 1084A/B/C Operation Manual for further information.

C.3.1 General Description

Option 02 incorporates a nickel-cadmium battery to back up memory circuits, which store data pertaining to GPS system parameters. Circuitry within the clock maintains the charge level of the battery during normal operation, and the battery preserves the data during power outages or when the clock is turned off.

The GPS backup battery supports the following functions and parameters: Function: Ephemeris Data;

Description: Information pertaining to satellite position or projected position, as a function of time.

Storing the above information will reduce the time needed to re-acquire satellite lock when the unit is turned on, or upon restoration of power after an outage.

NOTES:

1. There is no relationship between the GPS backup battery and the RAM backup battery included in a standard Model 1088A/B clock. The purpose of the standard RAM backup battery is to preserve the configuration settings for the instrument.
2. The standard Models 1083A, 1083B, 1084A/B/C and 1093A/B/C clocks do not contain a RAM backup battery because an EEPROM has replaced the RAM.

C.3.2 Specifications

Nickel-Cadmium, 3.6 volts, 60 mAh, Memory Retention Time: 2 months (approximate)

C.4 Option 03: Four Additional Outputs

C.4.1 General Description

Option 03 adds four rear-panel outputs, which may be configured to any available signal in the 1084A/B/C series clocks. Note that there are more jumper settings on the Option 03 board than the 1084A/B/C is capable of providing. The configuration of the four outputs can be changed at any time via internal jumper settings.

C.4.2 Specifications

General

Output Connectors: BNC-type RF connectors (4).

Analog Outputs

| | |
|----------------------|--|
| Output Type | Operational amplifier (LF353) output, with 557-ohm series resistor. |
| Available Outputs: | Note: All outputs available on clock Models 1088B, 1084A/B/C, 1093A/B/C and other clocks as noted. |
| IRIG-B, Modulated: | IRIG format B time code, modulated onto 1 kHz 10 Vpp sine wave carrier. Available on clock Model 1093A/B/C when equipped with Option 92, IRIG-B Modulated Output. |
| Deviation (1088A/B): | ± 5 volts analog, corresponding to 1-PPS deviation channel A or B (see individual clock Operation Manual). The proportion is 1 V per 10- μ s deviation (± 50 μ s full scale). |

C.4.3 Digital Outputs

| | |
|-------------------|--|
| Output Type: | High-Speed CMOS (74HC126), 0 to 5 volts, with 47 ohm series resistance. |
| Available Output: | <i>Note: All outputs available on Model 1088B and other clocks as noted.</i> |
| IRIG-B: | IRIG format B time code (unmodulated). <i>Available on clock Models 1088BP, 1084A/B/C and 1093A/B/C.</i> |

| | |
|-------------------------------|--|
| IRIG-E: | IRIG format E time code. |
| IRIG-H: | IRIG format H time code. |
| 10 MPPS: | 10,000,000 pulse-per-second (PPS) square wave, synchronous to the 1-PPS output. |
| 5 MPPS: | 5,000,000-PPS square wave, synchronous to the 1-PPS output. |
| 1 MPPS: | 1,000,000-PPS square wave, synchronous to the 1-PPS output. |
| 100 kPPS: | 100,000-PPS square wave, synchronous to the 1-PPS output. |
| 10 kPPS: | 10,000-PPS square wave, synchronous to the 1-PPS output. |
| 1 kPPS: | 1,000-PPS square wave, synchronous to the 1-PPS output. |
| 100 PPS: | 100-PPS square wave, synchronous to the 1-PPS output. |
| 60 PPS: | 60-PPS square wave, synchronous to the 1-PPS output. |
| 50 PPS: | 50-PPS square wave, synchronous to the 1-PPS output. |
| 10 PPS: | 10-PPS square wave, synchronous to the 1-PPS output. |
| IRIG-D/1 PPM: | IRIG format D time code (1 pulse per minute), rising edge on time. |
| 1 PPH: | 1 pulse per hour, rising edge on time. |
| 1 PPS: | (10 ms “high”), synchronous to 1 PPS/GPS. |
| Programmable: | Outputs a single pulse at a preprogrammed time, or a continuous pulse train having a period of one day or less. Pulse width is adjustable from 0.01 to 600 seconds. |
| Out-of-Lock: | Normally “HI” after acquisition of satellite signals. Toggles “LO” nn minutes after loss of satellite signal lock. Range for “nn” is 00 to 99 minutes, and is set using the SETUP menu or RS-232C (refer to clock Operation Manual). Setting of 00 disables this function (output remains “HI”). This output follows the standard “Out-of-Lock” function on the clock. |
| IRIG-B (Modified Manchester): | IRIG format “B” time code, Manchester encoded with 1-kPPS carrier, and data transitions on time mark. |

Changing Output Settings via Internal Settings

Case Removal

To change the configuration of Option 03, the top cover of the instrument must be removed. Turn off the instrument, and disconnect the power cord. Using a T-25 Torx driver, remove the four screws holding the cover (and rack mount ears, if used) in place, and lift the cover off.

WARNING Do not remove the top cover while power is applied. Hazardous voltages are present while the power cord is connected. Always disconnect the unit from the input power source before removal of the top cover.

General Information

Option 03 incorporates an extremely flexible output selection system using jumpers on the Option 03 printed circuit board. Each of the four rear-panel BNC-type I/O connectors, included with Option 03, can be configured to perform any of the available output functions. Figure 1 shows the locations and functions for all of the jumpers on the Option 03 board.

Function Selection

Jumpers JMP3 through JMP10 determine which output function their respective I/O connectors perform. The dotted lines in Figure 1 show the relationships between the jumper strips and the connectors. Set the jumper for each connector to the appropriate location for the type of output signal desired. Jumpers JMP4, 6, 8 and 10 refer to Output Function selections 1 and 2. Jumpers JMP3, 5, 7, and 9 refer to Output Function selections 3 through 22. The signals available are listed in the text to the left of the jumpers in Figure 1.

Mode Selection

In addition to specifying the output signal type for each individual connector, it is necessary to define whether the signal is analog or digital. This is accomplished using jumpers JMP11, JMP12, JMP14, and JMP15. Each of these jumpers corresponds to the output function jumper for one of the output connectors; the relationships are illustrated by the dotted lines in Figure C.1. Table C.1 shows the Function and Mode jumper settings for all of the various output signal types. Only the Modulated IRIG-B and Deviation outputs are analog; all others are digital.

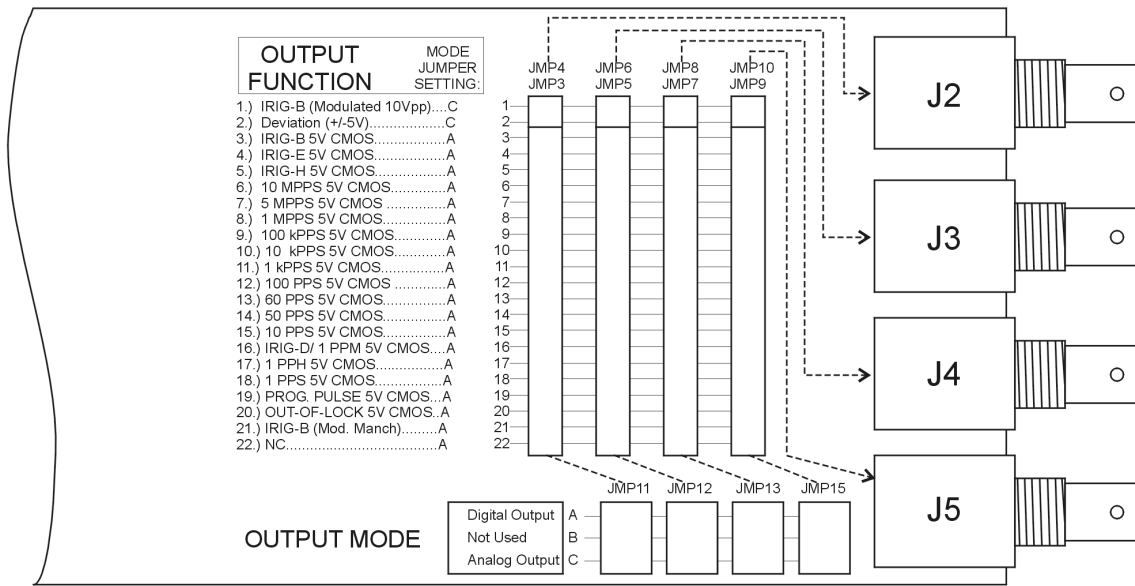

Figure C.1: Option 03 Jumper Configuration

| Output Signal | Function Select Jumper | Mode Select Jumper |
|----------------------|-------------------------------|---------------------------|
| IRIG-B Modulation | 1 | C |
| Deviation | 2 | C |
| IRIG-B | 3 | A |
| IRIG-E | 4 | A |
| IRIG-H | 5 | A |
| 10 MPPS | 6 | A |
| 5 MPPS | 7 | A |
| 1 MPPS | 8 | A |
| 100 kPPS | 9 | A |
| 10 kPPS | 10 | A |
| 1 kPPS | 11 | A |
| 100 PPS | 12 | A |
| 60 PPS | 13 | A |
| 50 PPS | 14 | A |
| 10 PPS | 15 | A |
| IRIG-D/1 PPM | 16 | A |
| 1 PPM | 17 | A |
| 1 PPS | 18 | A |
| Programmable Pulse | 19 | A |
| Out of Lock | 20 | A |
| IRIG-B Mod. Manch. | 21 | A |
| No Connection | 22 | A |

Table C.1: Output Connector Jumper Settings

C.5 Option 04: ON/OFF Switch

Option 04, ON/OFF switch for Satellite-Controlled clocks, can be mounted in Models 1084A/B only. Model 1084C LED uses the full front panel and Option 04 switch cannot be mounted.

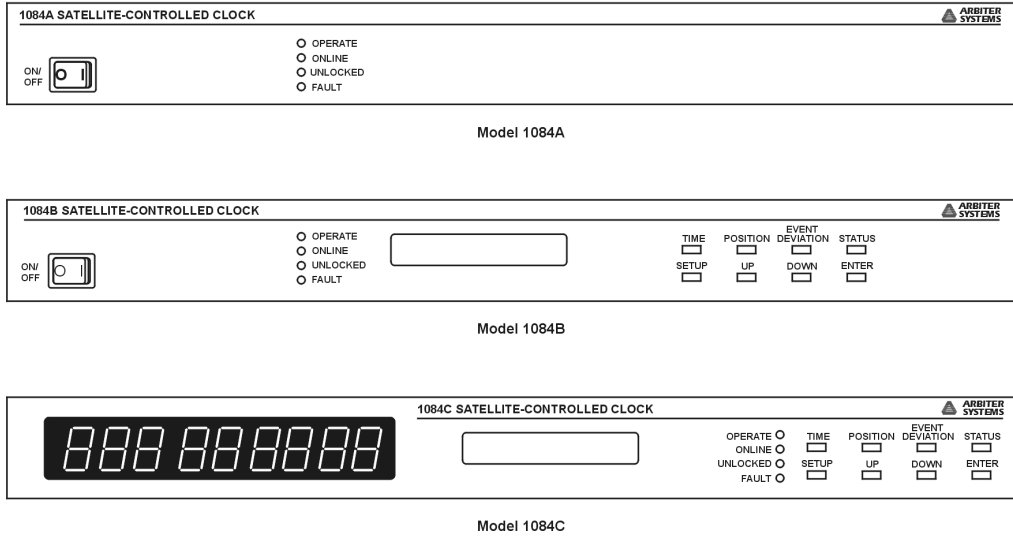

Figure C.2: Model 1084A/B/C Clocks

C.6 Option 06: Parallel BCD Output (1 millisecond Resolution)

C.6.1 General Description

Option 06 for the Model 1084A/B/C expands the capabilities of the instrument to include:

- Either of the following:
 - Time-of-year output in Binary-Coded Decimal (BCD) format, with resolution down to 1 millisecond;
 - Parallel Data output, with up to 48 bits that can be custom-configured at the factory for specific applications;
- A continuous 1 pulse-per-second (1 PPS) output, with the rising edge of a 10 millisecond-wide pulse synchronous to the rising edge of 1 PPS/GPS;
- A continuous 1,000 PPS (1 kPPS) square wave output, with rising edges synchronous to the rising edge of 1 PPS/GPS;
- Four pins of the output connector that can be configured with combinations* of the following:
 - Up to four digital signal outputs, the functions of which can be selected individually from 18 choices.
 - Up to two analog signal outputs, the functions of which can be selected individually from two choices.

***Note:** Since these auxiliary functions must share four connector pins, certain limitations will apply when selecting combinations:

1. Enabling any one (or more) of the digital signal outputs precludes four bits from the parallel data output, if used;
2. Each analog signal output used precludes one of the digital signal outputs; if two analog signal outputs are employed, only two digital signal outputs are possible. Also, each analog signal output displaces one bit from the parallel data interface, if used;

C.6.2 Option 06 Firmware Setup

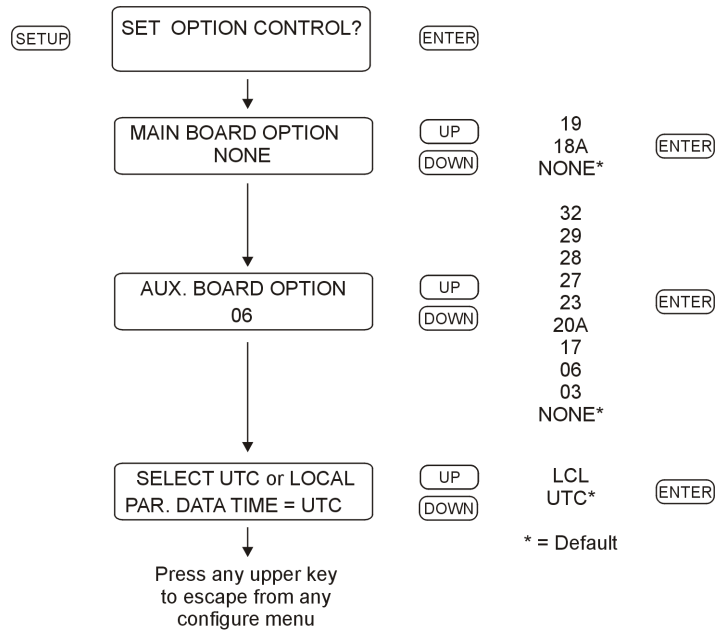

Figure C.3: Option 06 Firmware Setup

C.6.3 Specifications

General

Output Connector: 50 contact; Amphenol P/N 850-57L-40500-2700 or equivalent.

Mating Connectors:

Plastic: Amphenol P/N 850-57F-30500-20

Metal Shell: Amphenol P/N 850-57FE-30500-20

Parallel BCD Output

Data Bus Width: 42 bits. For weighting, refer to Table 1.

Output Type: High-Speed CMOS, buffered, (74HCXXX), 0 to 5 volts.

Time Data Format: UTC or Local time data; corresponds to setting for IRIG time data (see 1084A/B/C Operation Manual).

Time Accuracy: Rising edge delay of 100 nS maximum (1 mS bit), relative to 1 PPS output rising edge.

Analog Outputs

Output Type: Operational amplifier (LF353) output, with 562 ohm series resistor.

Pin Numbers: Output 1: pin 22

Output 2: pin 47

IRIG-B, Modulated: IRIG format B time code, modulated onto 1 kHz 10 V_{pp} sine wave carrier.

Deviation: Model 1088B Only; ± 5 volts analog, corresponding to 1 PPS deviation channel A or B.

C.6.4 Digital Outputs

| | |
|--------------------|---|
| Output Type: | High-Speed CMOS (74HCXXX), 0 to 5 volts, with 47 ohm series resistance. |
| Pin Numbers: | Output 1: pin 22 Output 2: pin 47 Output 3: pin 23 Output 4: pin 48 |
| Available Outputs: | |
| IRIG-B: | IRIG format B time code, 5 V CMOS (unmodulated). |
| IRIG-E: | IRIG format E time code, 5 V CMOS. |
| IRIG-H: | IRIG format H time code, 5 V CMOS. |
| IRIG-D/1 PPM: | IRIG format D time code (1 pulse per minute), 5 V CMOS. Rising edge on time. |
| 10 MPPS: | 10 MHz square wave, synchronous to the 1 PPS output. |
| 5 MPPS: | 5 MHz square wave, synchronous to the 1 PPS output. |
| 1 MPPS: | 1 MHz square wave, synchronous to the 1 PPS output. |
| 100 kPPS: | 100,000 PPS square wave, synchronous to the 1 PPS output. |
| 10 kPPS: | 10,000 PPS square wave, synchronous to the 1 PPS output. |
| 1 kPPS: | 1,000 PPS square wave, synchronous to the 1 PPS output. |
| 100 PPS: | 100 PPS square wave, synchronous to the 1 PPS output. |
| 60 PPS:* | 60 PPS square wave, synchronous to the 1 PPS output. |
| 50 PPS:* | 50 PPS square wave, synchronous to the 1 PPS output. |
| 10 PPS: | 10 PPS square wave, synchronous to the 1 PPS output. |
| 1 PPS: | 1 PPS (10 mS "high"), synchronous to 1 PPS/GPS. |
| 1 PPnnnS: | 1 pulse per "nnn" seconds (10 mS "high", synchronous to 1 PPS/GPS); "nnn" corresponds to a number of seconds entered by the user. |
| 1 PPH: | 1 pulse per hour, rising edge on time. |
| Out-of-Lock: | 5 volt CMOS levels. Normally "high" after acquisition of satellite signals. Toggles "low" nn minutes after loss of satellite signal lock. Range for "nn" is 00 to 99, and is set using the SETUP menu or RS-232C (refer to 1084A/B/C Operation Manual). Setting of 00 disables this function (output remains "high"). This output follows the standard "out-of-lock" function on the 1084A/B/C. |

* Available only with the Model 1088A/B series clocks.

C.6.5 Option 06 Connector Pin Designation

| Pin No: | BCD Mode Function/Bit Weighting: | Parallel Data Mode Function: |
|---------|-------------------------------------|---------------------------------|
| 1 | Ground | Ground |
| 2 | 1 PPS output | Data Bit 47 |
| *3 | Output 4 (Dig. only) | Data Bit 45 |
| *4 | Output 2 (Dig./An.) | Data Bit 27 |
| 5 | Day 200 | Data Bit 35 |
| 6 | Day 80 | Data Bit 43 |
| 7 | Day 20 | Data Bit 41 |
| 8 | Day 8 | Data Bit 39 |
| 9 | Day 2 | Data Bit 37 |
| 10 | 20 Hr. | Data Bit 33 |
| 11 | 8 Hr. | Data Bit 31 |
| 12 | 2 Hr. | Data Bit 29 |
| 13 | 40 Min. | Data Bit 26 |
| 14 | 10 Min. | Data Bit 24 |
| 15 | 4 Min. | Data Bit 22 |
| 16 | 1 Min. | Data Bit 20 |
| 17 | 20 Sec. | Data Bit 17 |
| 18 | 8 Sec. | Data Bit 15 |
| 19 | 2 Sec. | Data Bit 13 |
| 20 | 800 mS | Data Bit 11 |
| 21 | 200 mS | Data Bit 9 |
| 22 | 80 mS | Data Bit 7 |
| 23 | 20 mS | Data Bit 5 |
| 24 | 8 mS | Data Bit 3 |
| 25 | 2 mS | Data Bit 1 |
| 26 | Ground | Ground |
| 27 | 1 kPPS output | Data Bit 46 |
| *28 | Output 3 (Dig. only) | Data Bit 44 |
| *29 | Output 1 (Dig./An.) | Data Bit 19 |
| 30 | Day 100 | Data Bit 34 |
| 31 | Day 40 | Data Bit 42 |
| 32 | Day 10 | Data Bit 40 |
| 33 | Day 4 | Data Bit 38 |
| 34 | Day 1 | Data Bit 36 |
| 35 | 10 Hr. | Data Bit 32 |
| 36 | 4 Hr. | Data Bit 30 |
| 37 | 1 Hr. | Data Bit 28 |
| 38 | 20 Min. | Data Bit 25 |
| 39 | 8 Min. | Data Bit 23 |
| 40 | 2 Min. | Data Bit 21 |

| | | | |
|----|---------|-------------|---|
| 41 | 40 Sec. | Data Bit 18 | — |
| 42 | 10 Sec. | Data Bit 16 | — |
| 43 | 4 Sec. | Data Bit 14 | — |
| 44 | 1 Sec. | Data Bit 12 | — |
| 45 | 400 mS | Data Bit 10 | — |
| 46 | 100 mS | Data Bit 8 | — |
| 47 | 40 mS | Data Bit 6 | — |
| 48 | 10 mS | Data Bit 4 | — |
| 49 | 4 mS | Data Bit 2 | — |
| 50 | 1 mS | Data Bit 0 | — |

Table C.2: Option 06 Connector Pin Designation

*These pins can be configured for any of the listed functions, regardless of the main mode of operation for Option 06.

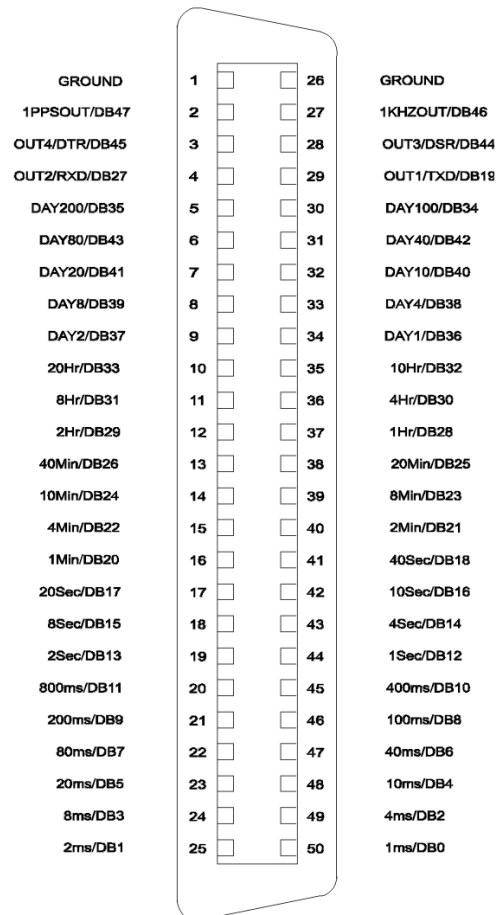

Figure C.4: Option 06 Output Connector

C.6.6 Configuration

General

Case Removal

To change the configuration of Option 06, the top cover of the instrument must be removed. Turn off the instrument, and disconnect the power cord. Using a T-25 driver, remove the four screws holding the cover (and rack mount ears, if used) in place, and lift the cover off.

WARNING: Do not remove the top cover while power is applied. Hazardous voltages are present while the power cord is connected. Always disconnect the unit from the input power source before removal of the top cover.

Jumper Functions and Locations

Upon removal of the top cover, locate the circuit board for Option 06 (a diagram of the board, showing jumper locations, is given in Figure 2). The following sections outline the jumper setting changes and other steps necessary to utilize the various features available with Option 06.

BCD Output Mode

General

When configured for BCD output of time data, Option 06 utilizes pins 1 through 21 and 26 through 46, along with ground pins 25 and 50. The weighting for the individual bits, along with the connector pin locations, is given in Table 1. To configure Option 06 for BCD operation, observe the following steps:

- a. Set jumper JMP1 to position "B". This enables the BCD output mode.
- b. Set jumper JMP6 to position "A". This jumper is included to set the timing mode when utilizing the parallel data output, and must be set to position "A" for the BCD output to function properly.

Operation in the BCD output mode allows use of the analog and/or digital signal outputs, the 1 PPS and 1 kPPS outputs. Refer to the appropriate sections of this document for details of these functions.

Time Data Format

The format of the BCD time data which is output from the rear-panel connector can be either Local time or Coordinated Universal Time (UTC), and will be the same as the time format which is specified in the SETUP menu for the IRIG time data outputs. For further details, refer to the flowchart titled "Set IRIG Time DATA?" in the 1084A/B/C Operation manual.

Parallel Data Output Mode

Full operation in the parallel data output mode utilizes all 50 contacts of the output connector. However, use of any combination of digital signal outputs or analog signal outputs will reduce the number of data bits available by up to four (data bits 19, 27, 44, and 45). For details, refer to the sections pertaining to these individual functions.

The functions of the individual data bits are defined for specific customer applications, upon request.

To configure Option 06 for parallel data mode, observe the following steps:

- a. Set jumper JMP1 to position "B". This jumper enables the parallel data output mode.
- b. Set jumpers JMP2, JMP3, JMP4, JMP5, and JMP11 to position "A" (these settings will vary if the analog and/or digital signal outputs are used; refer to the applicable sections for more information on these functions).
- c. If it is desired that the parallel output data be synchronous to the 1 PPS output, set jumper JMP6 to position "A"; for non-synchronous operation, set this jumper to position "B".

Digital Signal Outputs

The four digital signal outputs can be individually enabled and configured, using the following steps:

- a. Set jumper JMP11 to position "A". This enables the digital signal output mode. At the same time, making this jumper selection eliminates parallel data bits 19, 27, 44, and 45.
- b. To enable digital signal output number 1, set jumper JMP2 to position "A".
- c. To set the type of output signal for digital signal output number 1, make the appropriate selection on jumper JMP8 (refer to Figure 2). Note that positions 1 and 2 correspond to analog signal outputs, and will be occupied by a jumper only if analog signal output number 1 is enabled.
- d. To enable digital signal output number 2, set jumper JMP3 to position "A".
- e. To set the type of output signal for digital signal output number 2, make the appropriate selection on jumper JMP7 (refer to Figure 2). Note that positions 1 and 2 correspond to analog signal outputs, and will be occupied by a jumper only if analog signal output number 2 is enabled.
- f. To enable digital signal output number 3, set jumper JMP4 to position "A". This also eliminates the possibility of using analog signal output number 1.
- g. To set the type of output signal for digital signal output number 3, make the appropriate selection on jumper JMP9 (refer to Figure 2).
- h. To enable digital signal output number 4, set jumper JMP5 to position "A". This also eliminates the possibility of using analog signal output number 2.
- i. To set the type of output signal for digital signal output number 4, make the appropriate selection on jumper JMP10 (refer to Figure 2).

Analog Signal Outputs

The two analog signal outputs can be individually enabled and configured, using the following steps:

To enable analog signal output number 1, set jumper JMP4 to position "B". This setting also eliminates the possibility of having parallel data bit 44, digital signal output number 3.

To select the type of signal for analog output 1, remove the jumper from jumper strip JMP9 (which is no longer active, since it corresponds to digital signal output number 3), and place it on jumper strip JMP8 in either position 1 or 2 (refer to Figure 2).

To enable analog signal output number 2, set jumper JMP5 to position "B". This setting also eliminates the possibility of having parallel data bit 45, digital signal output number 4.

To select the type of signal for analog output 2, remove the jumper from jumper strip JMP10 (which is no longer active, since it corresponds to digital signal output number 4), and place it on jumper strip JMP7 in either position 1 or 2 (refer to Figure 2).

1 Pulse-per-Second (1 PPS) Output, 1,000 Pulse-per-Second (1 kPPS) Output

The 1 PPS and 1 kPPS outputs are enabled whenever Option 06 is placed in the BCD output mode (jumper JMP1 set to position "B").

| J2 Pin | Function | JMP1 | JMP2 | JMP3 | JMP4 | JMP5 | JMP6 | JMP11 |
|--------|--|------|------|------|------|------|------|-------|
| 22 | Synchronous (1 PPS) Parallel Data Bit 19 | A | A | -- | -- | -- | A | A |
| 22 | Asynchronous Parallel Data Bit 19 | A | A | -- | -- | -- | B | A |
| 22 | Digital Signal Output 1 | -- | A | -- | -- | -- | -- | B |
| 22 | RS-232C "T-D" | -- | B | -- | -- | -- | -- | -- |
| 47 | Synchronous (1 PPS) Parallel Data Bit 27 | A | -- | A | -- | -- | A | A |
| 47 | Asynchronous Parallel Data bit 19 | A | -- | A | -- | -- | B | A |
| 47 | Digital Signal Output 2 | -- | -- | A | -- | -- | -- | B |
| 47 | RS-232C "R-D" | -- | -- | B | -- | -- | -- | -- |
| 23 | Asynchronous Parallel Data Bit 44 | A | -- | -- | A | -- | -- | A |
| 23 | Digital Signal Output 3 | -- | -- | -- | A | -- | -- | B |
| 23 | RS-232C "DSR" | -- | -- | -- | C | -- | -- | -- |
| 23 | Analog Signal Output 1 | -- | -- | -- | B | -- | -- | -- |
| 48 | Asynchronous Parallel Data bit 45 | A | -- | -- | -- | A | -- | A |
| 48 | Digital Signal Output 4 | -- | -- | -- | -- | A | -- | B |
| 48 | RS-232C "DTR" | -- | -- | -- | -- | C | -- | -- |
| 48 | Analog Signal Output 2 | -- | -- | -- | -- | B | -- | -- |

Figure C.5: Option 06 Output Jumper Settings

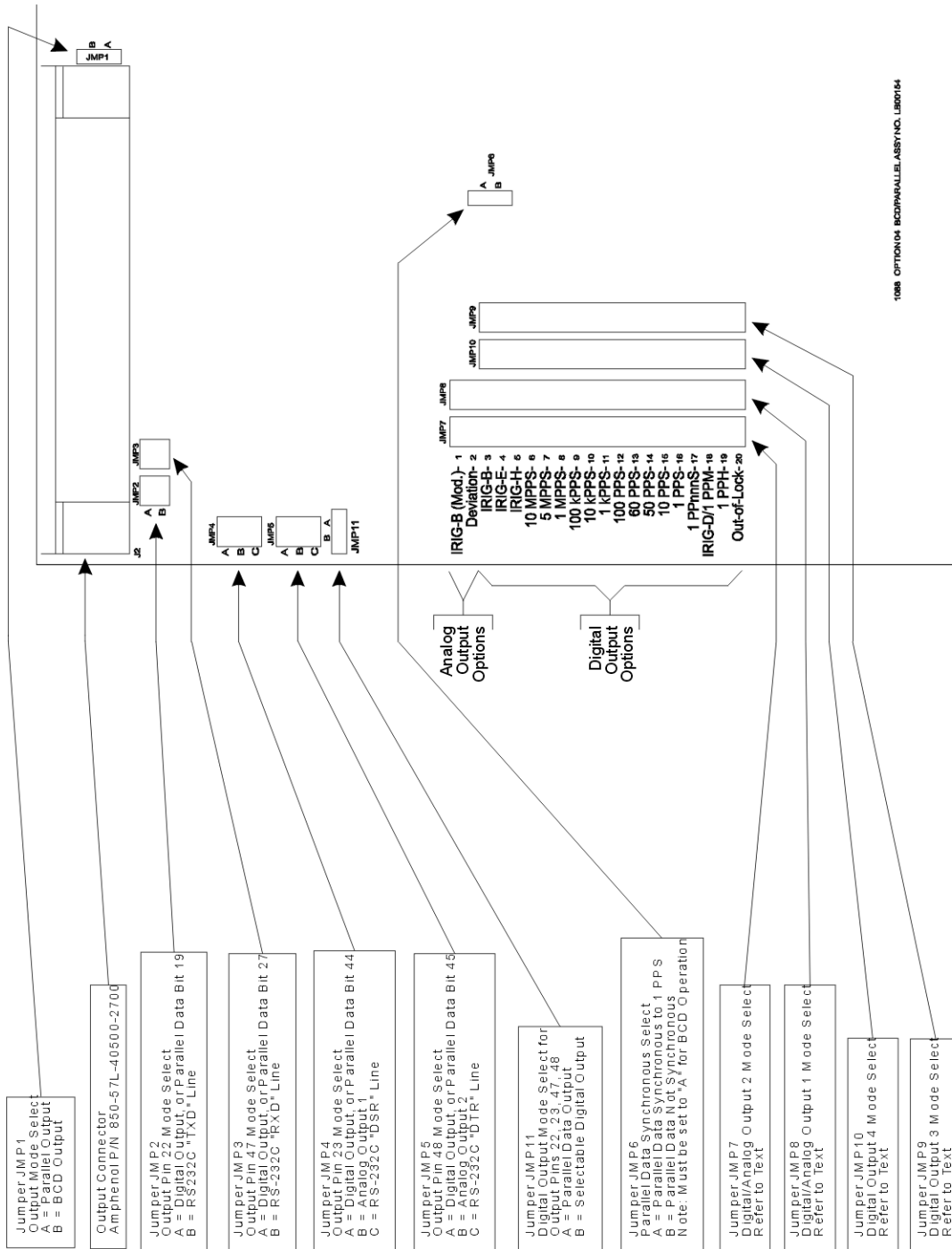

Figure C.6: Option 06 Board Layout and Jumper Locations

C.7 Option 07: Inlet Power Supply Description

C.7.1 85 to 264 Vac, 47 to 440 Hz, 110 to 370 Vdc, IEC-320 Connector

Option 07 provides an ac/dc power module, which includes an IEC-320 type inlet and mating ac cord. Input voltages are 85 to 264 Vac, 47 to 440 Hz or 110 to 370 Vdc, less than 20 Volt-Amps maximum. Various plug styles are available as Options P01 through P10. See Section 3.2.1 for a list of available cordsets.

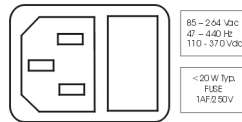

Figure C.7: Option 07 Power Supply Inlet Description

C.7.2 Specifications

Fuse

Type: Bussman GBD-1A
Current Rating: 1 Ampere, fast-acting.
Voltage Rating: 250 Volts.
Size: 5 mm x 20 mm.

Input Power

AC Voltage Range: 85 to 264 Vac.
Frequency Range: 47 to 440 Hz.
DC Voltage Range: 110 to 370 Vdc.

C.8 Option 08: Inlet Power Supply Description

C.8.1 10 to 60 Vdc ONLY, Terminal Power Strip, SWC

Option 08 replaces the standard IEC-320 power inlet module with a three-position, screw-type terminal block, including Surge Withstand Capability (SWC). With DC ONLY inlet voltages from 10 to 60 Vdc, this feature is intended for use in installations where it is necessary or desirable to have the instrument power hard-wired.

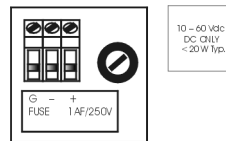

Figure C.8: Option 08 Power Supply Inlet Description

C.8.2 Specifications

Input Power

DC Voltage: 10 to 60 Vdc.
 Input Power: < 20 Watts, typical.

Terminal Strip

Terminal Assignment: Ground, (-), (+).
 Left to right, viewed from rear.
 Block Size: 49 mm W x 15 mm H x 16.5 mm D.
 (1.9" x 0.6" x 0.6")
 Block Material: Glass-filled thermoplastic.
 Screw Size: 6-32 x 1/4"
 Screw Material: Cadmium-plated steel.
 Terminal Spacing: 9 mm (0.35").
 Approvals: U.L. recognized; C.S.A. approved.

Fuse

Type: Bussman GDC-1A.
 Current Rating: 1 Ampere, time tag.
 Voltage Rating: 250 Volts.
 Size: 5 mm x 20 mm.

Surge Withstand Protection (SWC)

Provides input Surge Withstand Capability (SWC) in compliance with both ANSI C37.90 and IEC 801-4.

C.9 Option 10: Inlet Power Supply Description

C.9.1 110 to 370 Vdc, 85 to 264 Vac, 47 to 440 Hz Terminal Power Strip, SWC

Option 10 replaces the standard IEC-320 power input module with a three-position, screw-type terminal block, including Surge Withstand Capability (SWC). This feature is intended for use in installations where it is necessary or desirable to have the instrument power hard-wired. See Figure 3.3.

C.9.2 Specifications

Input Power:

| | |
|-------------------|-----------------|
| AC Voltage Range: | 85 to 264 Vac. |
| Frequency Range: | 47 to 440 Hz. |
| DC Voltage Range: | 110 to 370 Vdc. |

Terminal Block:

| | |
|-----------------------|--|
| Terminal Assignment:* | Ground, (-), (+), left to right, viewed from rear. |
| Block Size: | 15 mm W x 18 mm H x 30 mm D. (5/8" x 0.75" x 1 3/16"). |
| Approvals: | U. L. recognized; C.S.A. approved. |

*For AC operation, input line may be connected between (+) and (-), without regard to polarity; however proper grounding should always be employed.

Fuse:

| | |
|-----------------|------------------------|
| Type: | Bussman GDC-1A. |
| Current Rating: | 1 Ampere, fast-acting. |
| Voltage Rating: | 250 Volts. |
| Size: | 5 mm x 20 mm. |

Surge Withstand Protection (SWC)

Provides input Surge Withstand Capability (SWC) in compliance with both ANSI C37.90 and IEC 801-4.

Connections

All input power line connections to the rear-panel terminal strip should be made using appropriate power cables which have the insulation removed about 1/4" from the end or as required for tinning. If a DC source is used, connect the positive lead to the positive (+) terminal, connect the negative lead to the negative (-) terminal and a safety ground lead to the "G" terminal when viewing the instrument from the rear (see Figure 3.3).

C.10 Option 17: Parallel BCD Output and Second RS-232C Port

C.10.1 General Description

Option 17 for the standard Model 1084A/B/C and 1088A/B clocks expand the capabilities of the instrument to include:

- Either of the following:
 - a. Time-of-year output in Binary-Coded Decimal (BCD) format, with resolution down to 1 millisecond; or
 - b. Parallel Data output, with up to 48 bits that can be custom-configured at the factory for specific applications;
- A continuous 1 pulse-per-second (1 PPS) output, with the rising edge of a 10 millisecond-wide pulse synchronous to the rising edge of 1 PPS/GPS;
- A continuous 1,000 PPS (1 kPPS) square wave output, with rising edges synchronous to the rising edge of 1 PPS/GPS;
- Four pins of the output connector that can be configured with combinations* of the following:
 - a. Up to four digital signal outputs, the functions of which can be selected individually from 18 choices.
 - b. Up to two analog signal outputs, the functions of which can be selected individually from two choices.
 - c. An RS-232C serial communications port, which can use between two and four lines.

***Note:** Since these auxiliary functions must share four connector pins, certain limitations will apply when selecting combinations:

- Enabling any one (or more) of the digital signal outputs precludes four bits from the parallel data output, if used;
- Each analog signal output used precludes one of the digital signal outputs; if two analog signal outputs are employed, only two digital signal outputs are possible. Also, each analog signal output displaces one bit from the parallel data interface, if used;
- A two- or four-wire RS-232C port configuration uses two or four of the data output lines, so these lines become unavailable for digital and/or analog signal outputs, or for the assigned data bits of the parallel output (if used).

C.10.2 Option 17 Firmware Setup Procedure

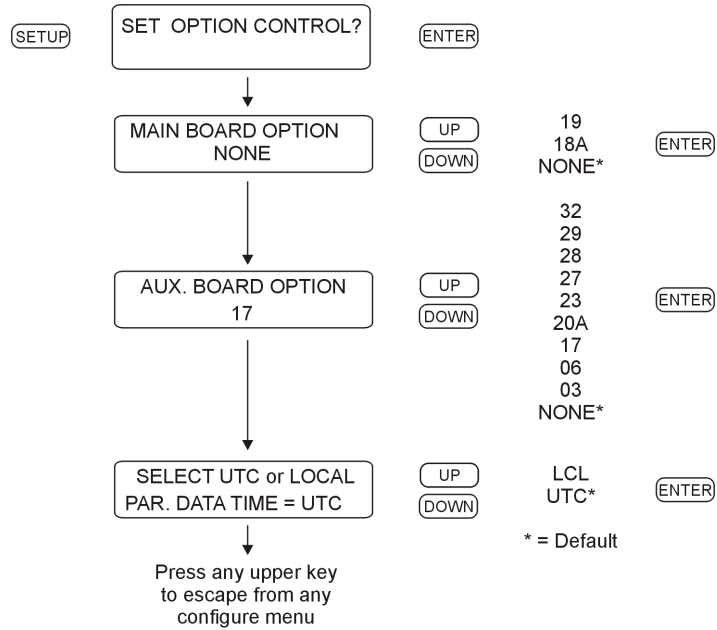

Figure C.9: Option 17 Firmware Setup

Note: For additional programming information on other options, please see 6 or other options in C.

C.10.3 Specifications

General

| | |
|--------------------|---|
| Output Connector: | 50 contact;Amphenol P/N 850-57L-40500-2700 or equivalent. |
| Mating Connectors: | |
| Plastic: | Amphenol P/N 850-57F-30500-20 |
| Metal Shell: | Amphenol P/N 850-57FE-30500-20 |

Parallel BCD Output

| | |
|-------------------|---|
| Data Bus Width: | 42 bits. For weighting, refer to Table 1. |
| Output Type: | High-Speed CMOS, buffered, (74HCXXX), 0 to 5 volts. |
| Time Data Format: | UTC or Local time data; corresponds to setting for IRIG time data (see 1084A/B/C Operation Manual). |
| Time Accuracy: | Rising edge delay of 100 nS maximum (1 mS bit), relative to 1 PPS output rising edge. |

Analog Outputs

| | |
|--------------------|--|
| Output Type: | Operational amplifier (LF353) output, with 562 ohm series resistor. |
| Pin Numbers: | Output 1: pin 22 Output 2: pin 47 |
| IRIG-B, Modulated: | IRIG format B time code, modulated onto 1 kHz 10 Vpp sine wave carrier. |
| Deviation: | Model 1088B Only; ± 5 volts analog, corresponding to 1 PPS deviation channel A or B. |

C.10.4 Digital Outputs

| | |
|--------------------|---|
| Output Type: | High-Speed CMOS (74HCXXX), 0 to 5 volts, with 47 ohm series resistance. |
| Pin Numbers: | Output 1: pin 22 Output 2: pin 47 Output 3: pin 23 Output 4: pin 48 |
| Available Outputs: | |
| IRIG-B: | IRIG format B time code, 5 V CMOS (unmodulated). |
| IRIG-E: | IRIG format E time code, 5 V CMOS. |
| IRIG-H: | IRIG format H time code, 5 V CMOS. |
| IRIG-D/1 PPM: | IRIG format D time code (1 pulse per minute), 5 V CMOS. Rising edge on time. |
| 10 MPPS: | 10 MHz square wave, synchronous to the 1 PPS output. |
| 5 MPPS: | 5 MHz square wave, synchronous to the 1 PPS output. |
| 1 MPPS: | 1 MHz square wave, synchronous to the 1 PPS output. |
| 100 kPPS: | 100,000 PPS square wave, synchronous to the 1 PPS output. |
| 10 kPPS: | 10,000 PPS square wave, synchronous to the 1 PPS output. |
| 1 kPPS: | 1,000 PPS square wave, synchronous to the 1 PPS output. |
| 100 PPS: | 100 PPS square wave, synchronous to the 1 PPS output. |
| 60 PPS:* | 60 PPS square wave, synchronous to the 1 PPS output. |
| 50 PPS:* | 50 PPS square wave, synchronous to the 1 PPS output. |
| 10 PPS: | 10 PPS square wave, synchronous to the 1 PPS output. |
| 1 PPS: | 1 PPS (10 mS "high"), synchronous to 1 PPS/GPS. |
| 1 PPnnnS: | 1 pulse per "nnn" seconds (10 mS "high", synchronous to 1 PPS/GPS); "nnn" corresponds to a number of seconds entered by the user. |
| 1 PPH: | 1 pulse per hour, rising edge on time. |
| Out-of-Lock: | 5 volt CMOS levels. Normally "high" after acquisition of satellite signals. Toggles "low" nn minutes after loss of satellite signal lock. Range for "nn" is 00 to 99, and is set using the SETUP menu or RS-232C (refer to 1084A/B/C Operation Manual). Setting of 00 disables this function (output remains "high"). This output follows the standard "out-of-lock" function on the 1084A/B/C. |

* Available only with the Model 1088A/B series clocks.

RS-232C

| | |
|------------------------------|--|
| Output Type: | CMOS, -12 to +12 volts. |
| Input Type: | Standard RS-232C levels. |
| <u>Inputs Available:</u> | |
| Receive Data (“RXD”): | Connector pin 4. Receives data from external device. Requires that JMP3 be set to position “B”. Precludes use of digital signal output 2 or parallel data bit 27. |
| Data Terminal Ready (“DTR”): | Connector pin 3. Informs clock that remote device is ready to receive data. Requires that JMP5 be set to position “C”. Precludes the use of digital signal output 4, analog signal output 2, or parallel data bit 45. |
| <u>Outputs Available:</u> | |
| Transmit Data (“TXD”): | Connector pin 29. Sends data to external device. Requires that JMP2 be set to position B. Precludes the use of digital signal output 1 or parallel data bit 19. |
| Data Set Ready (“DSR”): | Connector pin 28. Informs the remote device that clock is prepared to send data. Requires that JMP4 be set to position “C”. Precludes the use of digital signal output 3, analog signal output 1, or parallel data bit 44. |

C.10.5 Option 17 Connector Pin Designation

| Pin No: | BCD Mode Function/Bit Weighting: | Parallel Data Mode Function: | RS-232C Function |
|---------|-------------------------------------|---------------------------------|---------------------|
| 1 | Ground | Ground | Ground |
| 2 | 1 PPS output | Data Bit 47 | — |
| *3 | Output 4 (Dig. only) | Data Bit 45 | DTR |
| *4 | Output 2 (Dig./An.) | Data Bit 27 | RXD |
| 5 | Day 200 | Data Bit 35 | — |
| 6 | Day 80 | Data Bit 43 | — |
| 7 | Day 20 | Data Bit 41 | — |
| 8 | Day 8 | Data Bit 39 | — |
| 9 | Day 2 | Data Bit 37 | — |
| 10 | 20 Hr. | Data Bit 33 | — |
| 11 | 8 Hr. | Data Bit 31 | — |
| 12 | 2 Hr. | Data Bit 29 | — |
| 13 | 40 Min. | Data Bit 26 | — |
| 14 | 10 Min. | Data Bit 24 | — |
| 15 | 4 Min. | Data Bit 22 | — |
| 16 | 1 Min. | Data Bit 20 | — |
| 17 | 20 Sec. | Data Bit 17 | — |
| 18 | 8 Sec. | Data Bit 15 | — |
| 19 | 2 Sec. | Data Bit 13 | — |
| 20 | 800 mS | Data Bit 11 | — |
| 21 | 200 mS | Data Bit 9 | — |
| 22 | 80 mS | Data Bit 7 | — |
| 23 | 20 mS | Data Bit 5 | — |
| 24 | 8 mS | Data Bit 3 | — |
| 25 | 2 mS | Data Bit 1 | — |
| 26 | Ground | Ground | Ground |
| 27 | 1 kPPS output | Data Bit 46 | — |
| *28 | Output 3 (Dig. only) | Data Bit 44 | DSR |
| *29 | Output 1 (Dig./An.) | Data Bit 19 | TXD |
| 30 | Day 100 | Data Bit 34 | — |
| 31 | Day 40 | Data Bit 42 | — |
| 32 | Day 10 | Data Bit 40 | — |
| 33 | Day 4 | Data Bit 38 | — |
| 34 | Day 1 | Data Bit 36 | — |
| 35 | 10 Hr. | Data Bit 32 | — |
| 36 | 4 Hr. | Data Bit 30 | — |
| 37 | 1 Hr. | Data Bit 28 | — |
| 38 | 20 Min. | Data Bit 25 | — |
| 39 | 8 Min. | Data Bit 23 | — |
| 40 | 2 Min. | Data Bit 21 | — |

Table C.3: Option 17 Connector Pin Designation

Note: Table C.3 continued on next page.

Note: Table C.3 continued below.

| | | | |
|----|---------|-------------|---|
| 41 | 40 Sec. | Data Bit 18 | — |
| 42 | 10 Sec. | Data Bit 16 | — |
| 43 | 4 Sec. | Data Bit 14 | — |
| 44 | 1 Sec. | Data Bit 12 | — |
| 45 | 400 mS | Data Bit 10 | — |
| 46 | 100 mS | Data Bit 8 | — |
| 47 | 40 mS | Data Bit 6 | — |
| 48 | 10 mS | Data Bit 4 | — |
| 49 | 4 mS | Data Bit 2 | — |
| 50 | 1 mS | Data Bit 0 | — |

*These pins can be configured for any of the listed functions, regardless of the main mode of operation for Option 17.

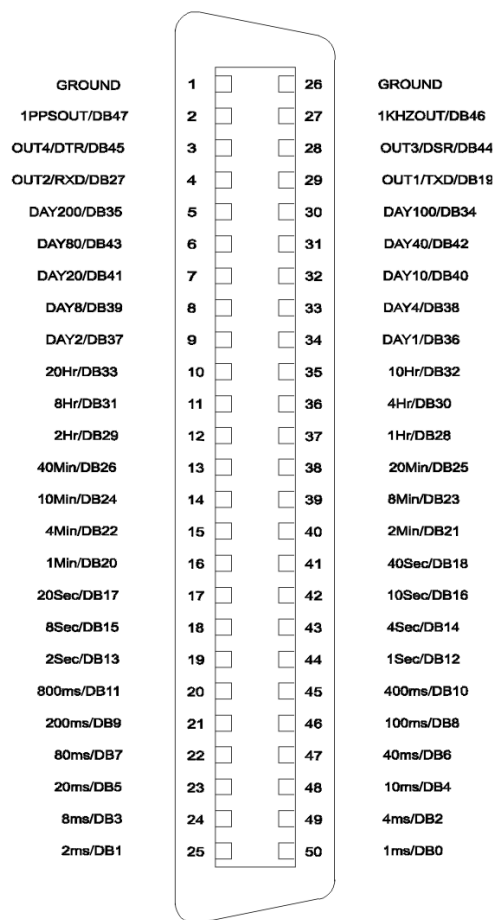

Figure C.10: Option 17 Output Connector

C.10.6 Configuration

General

Case Removal

To change the configuration of Option 06, the top cover of the instrument must be removed. Turn off the instrument, and disconnect the power cord. Using a T-25 driver, remove the four screws holding the cover (and rack mount ears, if used) in place, and lift the cover off.

WARNING: Do not remove the top cover while power is applied. Hazardous voltages are present while the power cord is connected. Always disconnect the unit from the input power source before removal of the top cover.

Jumper Functions and Locations

Upon removal of the top cover, locate the circuit board for Option 06 (a diagram of the board, showing jumper locations, is given in Figure 2). The following sections outline the jumper setting changes and other steps necessary to utilize the various features available with Option 06.

BCD Output Mode

General

When configured for BCD output of time data, Option 06 utilizes pins 1 through 21 and 26 through 46, along with ground pins 25 and 50. The weighting for the individual bits, along with the connector pin locations, is given in Table 1. To configure Option 06 for BCD operation, observe the following steps:

- a. Set jumper JMP1 to position "B". This enables the BCD output mode.
- b. Set jumper JMP6 to position "A". This jumper is included to set the timing mode when utilizing the parallel data output, and must be set to position "A" for the BCD output to function properly.

Operation in the BCD output mode allows use of the analog and/or digital signal outputs, the 1 PPS and 1 kPPS outputs, and the RS-232C communications port. Refer to the appropriate sections of this document for details of these functions.

Time Data Format

The format of the BCD time data which is output from the rear-panel connector can be either Local time or Coordinated Universal Time (UTC), and will be the same as the time format which is specified in the SETUP menu for the IRIG time data outputs. For further details, refer to the flowchart titled "Set IRIG Time DATA?" in the 1084A/B/C Operation manual.

Parallel Data Output Mode

Full operation in the parallel data output mode utilizes all 50 contacts of the output connector. However, use of any combination of digital signal outputs or analog signal outputs, or RS-232C will reduce the number of data bits available by up to four (data bits 19, 27, 44, and 45). For details, refer to the sections pertaining to these individual functions.

The functions of the individual data bits are defined for specific customer applications, upon request.

To configure Option 06 for parallel data mode, observe the following steps:

- a. Set jumper JMP1 to position "B". This jumper enables the parallel data output mode.
- b. Set jumpers JMP2, JMP3, JMP4, JMP5, and JMP11 to position "A" (these settings will vary if the analog and/or digital signal outputs or RS-232C port are used; refer to the applicable sections for more information on these functions).
- c. If it is desired that the parallel output data be synchronous to the 1 PPS output, set jumper JMP6 to position "A"; for non-synchronous operation, set this jumper to position "B".

Digital Signal Outputs

The four digital signal outputs can be individually enabled and configured, using the following steps:

- a. Set jumper JMP11 to position "A". This enables the digital signal output mode. At the same time, making this jumper selection eliminates parallel data bits 19, 27, 44, and 45.
- b. To enable digital signal output number 1, set jumper JMP2 to position "A". This also eliminates the TXD RS-232C line.
- c. To set the type of output signal for digital signal output number 1, make the appropriate selection on jumper JMP8 (refer to Figure 2). Note that positions 1 and 2 correspond to analog signal outputs, and will be occupied by a jumper only if analog signal output number 1 is enabled.
- d. To enable digital signal output number 2, set jumper JMP3 to position "A".
- e. To set the type of output signal for digital signal output number 2, make the appropriate selection on jumper JMP7 (refer to Figure 2). Note that positions 1 and 2 correspond to analog signal outputs, and will be occupied by a jumper only if analog signal output number 2 is enabled.
- f. To enable digital signal output number 3, set jumper JMP4 to position "A". This also eliminates the possibility of using analog signal output number 1.
- g. To set the type of output signal for digital signal output number 3, make the appropriate selection on jumper JMP9 (refer to Figure 2).
- h. To enable digital signal output number 4, set jumper JMP5 to position "A". This also eliminates the possibility of using analog signal output number 2.
- i. To set the type of output signal for digital signal output number 4, make the appropriate selection on jumper JMP10 (refer to Figure 2).

Analog Signal Outputs

The two analog signal outputs can be individually enabled and configured, using the following steps:

To enable analog signal output number 1, set jumper JMP4 to position "B". This setting also eliminates the possibility of having parallel data bit 44, digital signal output number 3.

To select the type of signal for analog output 1, remove the jumper from jumper strip JMP9 (which is no longer active, since it corresponds to digital signal output number 3), and place it on jumper strip JMP8 in either position 1 or 2 (refer to Figure 2).

To enable analog signal output number 2, set jumper JMP5 to position "B". This setting also eliminates the possibility of having parallel data bit 45, digital signal output number 4.

To select the type of signal for analog output 2, remove the jumper from jumper strip JMP10 (which is no longer active, since it corresponds to digital signal output number 4), and place it on jumper strip JMP7 in either position 1 or 2 (refer to Figure 2).

1 Pulse-per-Second (1 PPS) Output, 1,000 Pulse-per-Second (1 kPPS) Output

The 1 PPS and 1 kPPS outputs are enabled whenever Option 06 is placed in the BCD output mode (jumper JMP1 set to position "B").

| J2 Pin | Function | JMP1 | JMP2 | JMP3 | JMP4 | JMP5 | JMP6 | JMP11 |
|--------|--|------|------|------|------|------|------|-------|
| 22 | Synchronous (1 PPS) Parallel Data Bit 19 | A | A | -- | -- | -- | A | A |
| 22 | Asynchronous Parallel Data Bit 19 | A | A | -- | -- | -- | B | A |
| 22 | Digital Signal Output 1 | -- | A | -- | -- | -- | -- | B |
| 22 | RS-232C "T-D" | -- | B | -- | -- | -- | -- | -- |
| 47 | Synchronous (1 PPS) Parallel Data Bit 27 | A | -- | A | -- | -- | A | A |
| 47 | Asynchronous Parallel Data bit 19 | A | -- | A | -- | -- | B | A |
| 47 | Digital Signal Output 2 | -- | -- | A | -- | -- | -- | B |
| 47 | RS-232C "R-D" | -- | -- | B | -- | -- | -- | -- |
| 23 | Asynchronous Parallel Data Bit 44 | A | -- | -- | A | -- | -- | A |
| 23 | Digital Signal Output 3 | -- | -- | -- | A | -- | -- | B |
| 23 | RS-232C "DSR" | -- | -- | -- | C | -- | -- | -- |
| 23 | Analog Signal Output 1 | -- | -- | -- | B | -- | -- | -- |
| 48 | Asynchronous Parallel Data bit 45 | A | -- | -- | -- | A | -- | A |
| 48 | Digital Signal Output 4 | -- | -- | -- | -- | A | -- | B |
| 48 | RS-232C "DTR" | -- | -- | -- | -- | C | -- | -- |
| 48 | Analog Signal Output 2 | -- | -- | -- | -- | B | -- | -- |

Figure C.11: Option 17 Output Jumper Settings

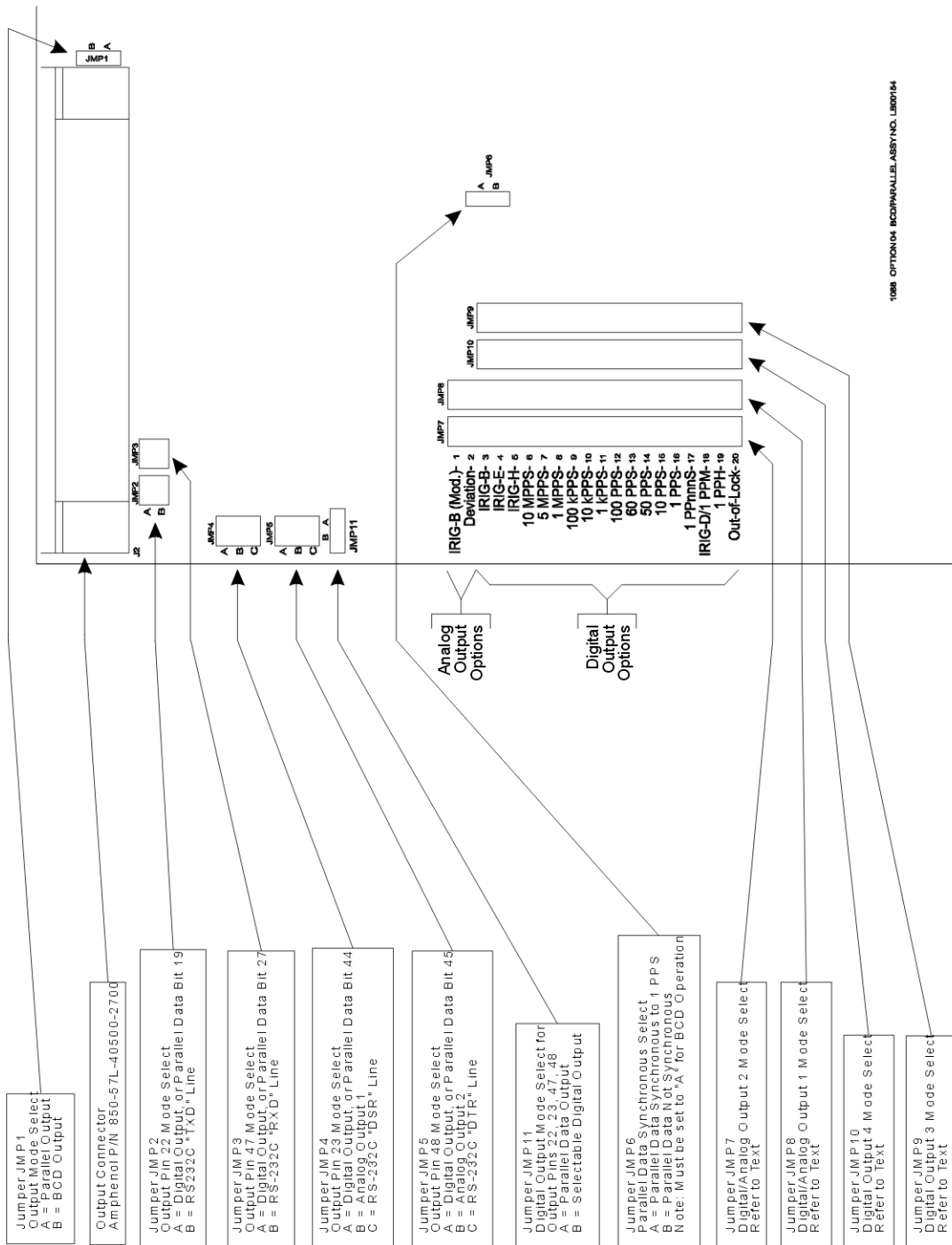

Figure C.12: Option 17 Board Layout and Jumper Locations

C.11 Option 19: Second RS-232C Interface

C.11.1 General Description

Option 19 for the Model 1084A/B/C adds a second RS-232C port, allowing communications and control via a second 9-pin connector on the rear panel. The second RS-232C port connector is initially installed in units without the option. Option 19 requires the installation of internal components.

C.11.2 Specification

Commands

All commands, which are available for the main RS-232C port on the Model 1084A/B/C, may be used with Option 19. See Chapter 9 for list of RS-232 commands. Note that broadcast commands supporting the main RS-232 port begin with the letter “B” and broadcast commands supporting the second RS-232 port begin with the letter “O”. For example, to broadcast ASCII from the main RS-232 port, type “B1.” To broadcast ASCII from the second RS-232 port, type “O1.”

RS-232 Connector Pin Locations

The connector pin locations of the RS-232 connector is as follows:

| Pin | Pin Definition |
|-----|----------------------------|
| 1 | No Connection |
| 2 | Receive Data input (RXD) |
| 3 | Transmit Data output (TXD) |
| 4 | Programmable Pulse Output |
| 5 | Signal Common |
| 6 | No Connection |
| 7 | No Connection |
| 8 | No Connection |
| 9 | No Connection |

Table C.4: Option 19, Second RS-232 Port Pin Locations

C.12 Option 20A: Four Fiber Optic Outputs

Purpose

When installed into the standard Model 1093A/B/C, 1084A/B/C or 1088B, Option 20A provides four individually selectable fiber-optic outputs with Type ST connectors and 820-nm transmitters compatible with multi-mode fiber.

Specifications

Each fiber-optic output is jumper-configurable to each of the standard digital (CMOS) signal outputs. Analog signals, IRIG-B Modulated, and ± 5 V Recorder are not selectable.

Option 20A provides an optical power output of -15 dBm minimum (-12 dBm typical) into 62.5/125- μ m fiber.

The optical signal is ON whenever the selected logic signal is HI. Transmitter bandwidth is compatible with all available logic signals.

Option 20A may be installed in Slot A of Model 1084A/B/C, in either Slot A or B of the standard Model 1088A/B clock and in Slot A of Model 1093A/B/C clock.

Output Enable (JMP1)

This jumper is used at the factory for setting the output enable for the optical transmitters. For normal operation, set jumper to position "A". With two clocks containing Option 18 and configured for redundant operation, this jumper may be set to position "B", allowing the optical outputs to be externally paralleled and driven by the on-line clock. Normally, this jumper will be configured as required when delivered from the factory.

Output Jumper Enable (JMP2 – JMP5)

The standard digital (CMOS) output signals can be selected for output via one of the fiber-optic output transmitters by setting jumpers JMP2 through JMP5 on the Fiber-Optic Option Board as illustrated in Figure C.13.

The following tables provide a list of jumper to corresponding output transmitter and a list digital signals available for configuration to a fiber-optic output connector. The same signals are available via each jumper (JMP2 - JMP5) and corresponding setting.

| Output Transmitter | Jumper | Pin | Signal | Notes |
|--------------------|--------|-----|--------------------|---------|
| CR1 | JMP2 | 1 | IRIG-B | 1, 2, 3 |
| CR2 | JMP3 | 2 | IRIG-E | 2, 3 |
| CR3 | JMP4 | 3 | IRIG-H | 2, 3 |
| CR4 | JMP5 | 4 | 10 MPPS | 2, 3 |
| – | – | 5 | 5 MPPS | 2, 3 |
| – | – | 6 | 1 MPPS | 2, 3 |
| – | – | 7 | 100 kPPS | 2, 3 |
| – | – | 8 | 10 kPPS | 2, 3 |
| – | – | 9 | 1 kPPS | 2, 3 |
| – | – | 10 | 100 PPS | 2, 3 |
| – | – | 11 | 60 PPS | 2 |
| – | – | 12 | 50 PPS | 2 |
| – | – | 13 | 10 PPS | 2, 3 |
| – | – | 14 | 1 PPM | 2, 3 |
| – | – | 15 | 1 PPH | 2, 3 |
| – | – | 16 | 1 PPS | 1, 2, 3 |
| – | – | 17 | Prog. Pulse | 1, 2, 3 |
| – | – | 18 | IRIG-B Mod. Manch. | 2, 3 |

Table C.5: Option 20A, Four Fiber Optic Output Configuration

1. Signals available on the Model 1093A/B/C
2. Signals available on the Model 1088A/B
3. Signals available on the Model 1084A/B/C

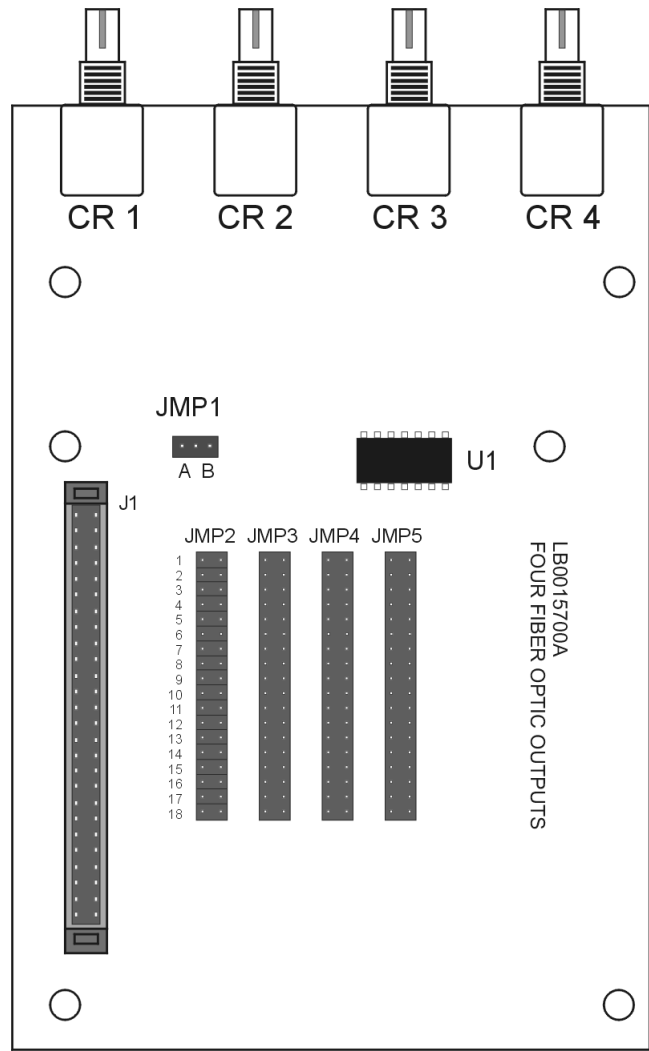

Figure C.13: Option 20A Jumper Locations

C.13 Option 23, COMTRADE Sample Rate Generator

C.13.1 General Description

When equipped with the Option 23 COMTRADE Sample Rate Generator, the Satellite-Controlled Clock generates any one of the 48 standard sampling rates for waveform digitization in 50 or 60 Hz systems which are defined in IEEE Standard C37.111-1991, Data Exchange (COMTRADE) for Power Systems. Standard COMTRADE Sampling Rates are listed in Tables 1 and 2 (on following page).

The selected sample rate is available as a 5 V CMOS-level square wave in both normal (rising edge of clock synchronous with 1 PPS) and complemented (falling edge of clock synchronous with 1 PPS) polarities. The sampling pulse is synchronized to within 50 ns of 1 PPS, and has sample-to-sample jitter less than 1 ns.

C.13.2 Principles of Operation

The Option 23 assembly generates sampling signals, which are precisely locked to 1 PPS-GPS by phase locking a precision voltage-controlled crystal oscillator (VCXO) to the internal 1 kPPS signal present in the clock. This VCXO output signal is then divided down to obtain the desired sampling rate. Synchronization logic is also provided, to ensure that the output divider is synchronized to 1 PPS-GPS. By using a precision VCXO, pulse-to-pulse sampling jitter is held to an absolute minimum, and is specified not to exceed 1 ns rms. The output signals have a 50% duty cycle (square wave).

C.13.3 Other Features

The Option 23 assembly includes four configurable BNC outputs, which are in addition to those available for the standard model clock. Either normal or complemented-polarity COMTRADE sampling frequency signals may be made available at each of these additional outputs. Furthermore, any output not configured for a COMTRADE sampling rate output can be used as a general-purpose configurable output, and can deliver any of the 21 standard signals available in the Model 1084A/B/C. The Option 23 assembly may be installed in the standard option slot available (Slot B).

C.13.4 Specifications

Sampling Rates

| Samples/cycle | f_s for 60 Hz | f_s for 50 Hz |
|---------------|-----------------|-----------------|
| 384 | 23040 | 19200 |
| 192 | 11520 | 9600 |
| 128 | 7680 | 6400 |
| 96 | 5760 | 4800 |
| 64 | 3840 | 3200 |
| 48 | 2880 | 2400 |
| 32 | 1920 | 1600 |
| 24 | 1440 | 1200 |
| 16 | 960 | 800 |
| 12 | 720 | 600 |
| 8 | 480 | 400 |
| 6 | 360 | 300 |
| 4 | 240 | 200 |

Table C.6: Option 23, Sample Rates, $f_{LCM} = 384 \times f_{base}$

| Samples/cycle | f_s for 60 Hz | f_s for 50 Hz |
|---------------|-----------------|-----------------|
| 3200 | 192000 | 160000 |
| 1600 | 96000 | 80000 |
| 800 | 48000 | 40000 |
| 640 | 38400 | 32000 |
| 400 | 24000 | 20000 |
| 320 | 19200 | 16000 |
| 200 | 12000 | 10000 |
| 160 | 9600 | 8000 |
| 128 | 7680 | 6400 |
| 100 | 6000 | 5000 |
| 80 | 4800 | 4000 |
| 64 | 3840 | 3200 |
| 50 | 3000 | 2500 |
| 40 | 2400 | 2000 |
| 32 | 1920 | 1600 |
| 20 | 1200 | 1000 |
| 16 | 960 | 800 |
| 10 | 600 | 500 |
| 8 | 480 | 400 |
| 4 | 240 | 200 |

Table C.7: Option 23, Sample Rates, $f_{LCM} = 3200 \times f_{base}$

C.13.5 Performance

Accuracy: ± 50 ns from 1 PPS, max (-10 ns, typical)
 Jitter: 1 ns rms, max. pulse to pulse (guaranteed by design, not production tested)

C.13.6 Outputs

Connectors: Four, BNC 50-ohm, configurable
 Signals: Normal Polarity COMTRADE Sample Rate, 50% Duty Cycle
 Complemented COMTRADE Sample Rate, 50% Duty Cycle
 All 21 Other Signals Available in 1088B or 1084A/B/C Clock

C.13.7 Drive Capability

Digital: 5 V CMOS Buffer, 50 Ohms Impedance
 Analog: Op amp Buffer, 600 Ohms Impedance

C.13.8 Setup

Setup Menu

The SETUP menu allows the user to modify internal operating firmware parameters within both the Model 1084A/B/C and Model 1088A/B. The SETUP menu can be easily accessed from the front panel keyboard.

The Option 23 SETUP menu is illustrated in Figure 5-1 for the standard clock Model 1084A/B/C. Figure 5-2 illustrates the standard Model 1088A/B SETUP menu. However, for clarity only Option 23 is described.

RS-232C Commands

Option 23 can also be configured via the RS-232C interface using one of the following commands:

Configure Option 23

Command: **m:rCA, m:rCB**

m:rCA configures Option 23 to operate correctly from Option Slot A in the Model 1084A/B/C, or from the Model 1088B. m:rCB configures Option 23 to operate correctly from Option Slot B from the Model 1088B only.

Response: \triangleright

Where:

| | |
|---|--|
| m | 0 = 50 Hz |
| | 1 = 60 Hz |
| r | see Table C.6 or Table C.7 for SAMPLES/CYCLE number. |

C.13.9 Option 23, Front Panel Setup

The information provided on this page should help you to configure the Option 23 on the Model 1084A/B/C clocks. If you should need additional information on setting up from the front panel keys, please go to Chapter 9 on page 65.

To enter the Aux Board Setup menu, press **SETUP**, until you reach **SET OPTION CONTROL**, then press **ENTER**. Make choices using the **UP/DOWN** keys to select the desired value and **ENTER** key to confirm the selection and move on.

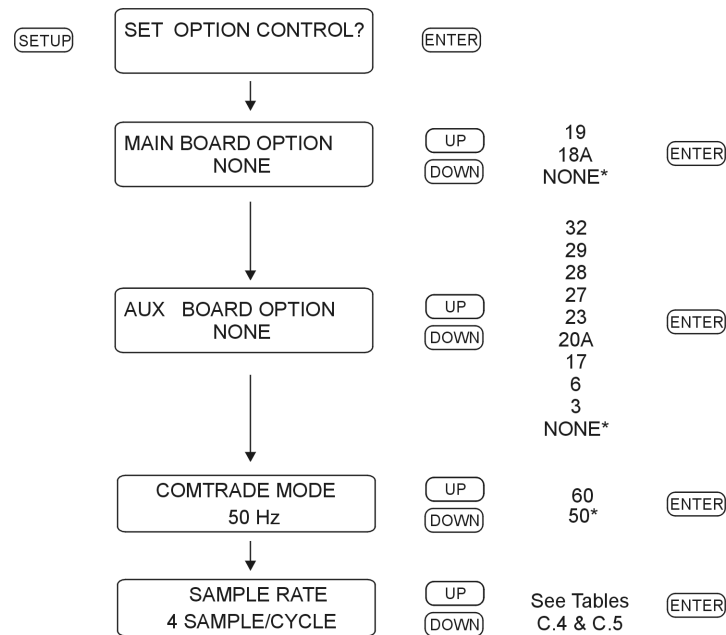

Figure C.14: Option 23 Front Panel Setup

C.13.10 Changing Hardware Settings via Internal Jumpers

It is necessary to set a jumper in order to assign the output signal to a specific I/O connector. The following paragraphs describe the procedure for setting these jumpers.

Cover Removal

To change the I/O configuration of the rear-panel connectors, the top cover of the instrument must be removed. Turn off the instrument, and disconnect the power cord. Using a T-25 driver, remove the four screws holding the cover (and rack mount ears, if used) in place, and lift the cover off.

WARNING: DO NOT REMOVE top cover while power is applied. Hazardous voltages are present while the power cord is connected. Always disconnect the unit from the input power source before removal of the top cover.

The Option 23 COMTRADE Board is illustrated in Figure 6-1, which shows the location of all the jumpers along with a brief description.

Output Function Selection

Jumpers JMP1, JMP2, JMP3, and JMP4 determine the output signals which can be made available at I/O connectors J2, J3, J4, and J5, respectively. Figure C.15 illustrates the relationship between these jumpers and the I/O connectors. The first step in setting an I/O channel for a specific output signal is to move the associated jumper to the location corresponding to the desired signal. Table C.8 lists the jumper settings required for various signals.

Output Mode Selection

The next step in configuring the I/O connectors is to determine whether the assigned signal is an analog output or a digital output. This selection is accomplished by setting jumpers JMP5, JMP6, JMP7, and JMP8 to the appropriate positions. These jumpers correspond to connectors J2, J3, J4, and J5, respectively (see Figure C.15). If the I/O channel is to be used as a digital output, the corresponding jumper should be set to position "A". If the I/O channel is to be used as an analog output, the jumper should be set to position "C". Table C.8 lists jumper positions for individual output signals.

| Output Signal | Function Jumpers | Mode Jumpers |
|--------------------------------|-------------------------|---------------------|
| IRIG-B Modulated, 10 Vpp | 1 | C |
| Deviation (± 5 V) | 2 | C |
| IRIG-B | 3 | A |
| IRIG-E | 4 | A |
| IRIG-H | 5 | A |
| 10 MPPS | 6 | A |
| 5 MPPS | 7 | A |
| 1 MPPS | 8 | A |
| 100 kPPS | 9 | A |
| 10 kPPS | 10 | A |
| 1 kPPS | 11 | A |
| 100 PPS | 12 | A |
| 60 PPS | 13 | A |
| 50 PPS | 14 | A |
| 10 PPS | 15 | A |
| IRIG-D/1 PPM | 16 | A |
| 1 PPH | 17 | A |
| 1 PPS | 18 | A |
| Programmable Pulse | 19 | A |
| Out of Lock | 20 | A |
| IRIG-B Modified Manchester | 21 | A |
| Normal Polarity COMTRADE | 22 | A |
| Complemented Polarity COMTRADE | 23 | A |

Table C.8: Option 23, Output Signal Selection Jumper Settings

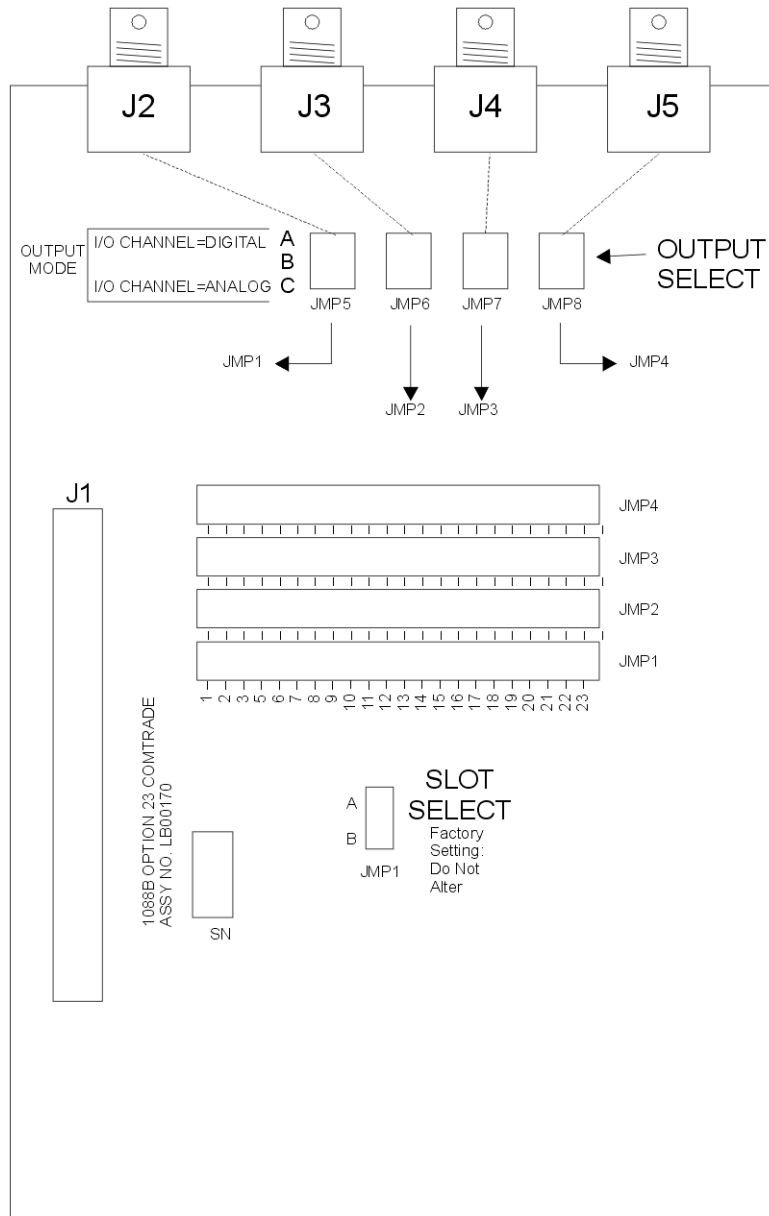

Figure C.15: Option 23 Internal Jumper Setup

C.14 Option 27: 8-Channel High Drive

C.14.1 General Description

Option 27 provides eight independent, IRIG-B buffered outputs, each capable of driving multiple loads. Outputs are short circuit and surge protected. Each output is individually configurable for either modulated or unmodulated IRIG-B signals via jumper settings as illustrated in Figure C.16.

C.14.2 Specifications

Output Selection Each output is jumper selectable for either a Modulated or Unmodulated signal. See Figure C.16 for jumper locations and configuration settings.

Number of Channels: Eight (8).

Signal Levels:

Modulated: 4.5 V_{pp} with 20-Ohm source impedance; each channel will drive a 50-Ohm load to 3 V_{pp} minimum; requires Option 92 in Model 1093A/B/C.

Unmodulated: +5-V open-circuit; +4 V minimum at 250-mA load
load current each channel will drive 25 Schweitzer
SEL-3xx (in parallel) or 50 SEL-2xx (in series/parallel)
relays at 10 mA per relay.

Maximum Load (per driver):

Modulated: No Limit: will drive a short circuit.

Unmodulated: 250-mA peak current; pulse-by-pulse shutdown if load
current exceeds internal limit (self-resetting).

Output Connector

16-position pluggable 5-mm (Phoenix-type) terminal strip with eight 2-position mating connectors.

C.14.3 Option Setup

Using Front Panel Keys

To set up Option 27 from the front-panel keys, please follow the guidelines in Section 6.12, on page 50.

Using RS-232C Port

To set up Option 27 using the RS-232C port, please follow the guidelines in Section 9.2.13 on page 87.

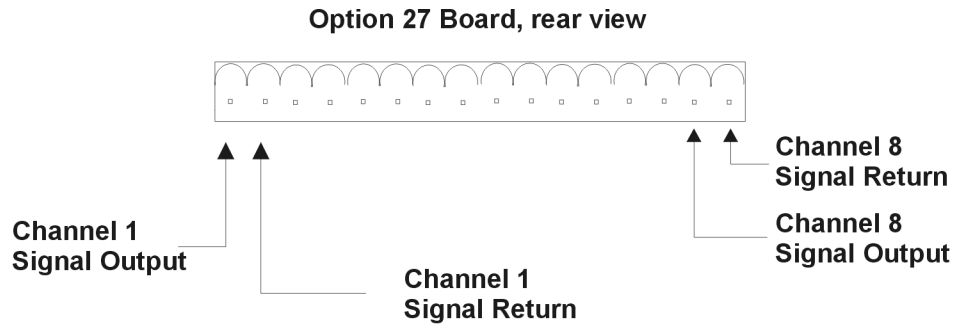

16-position I/O Connector with eight 2-position mating connectors.

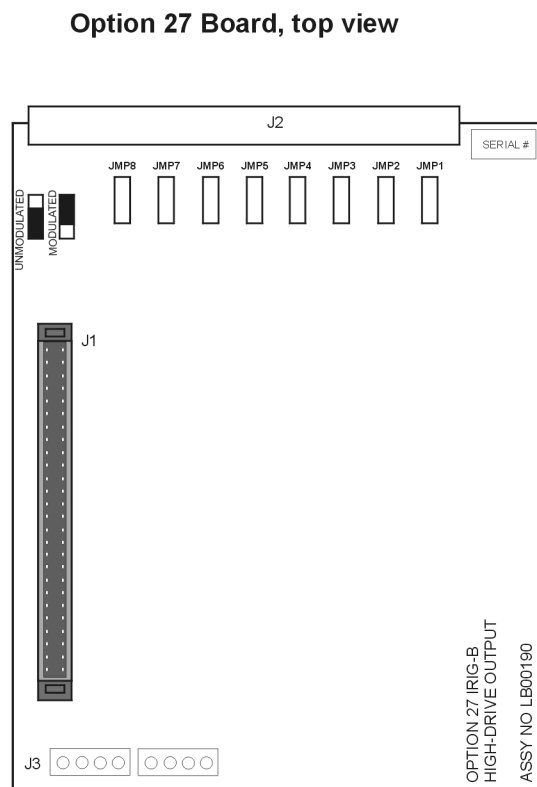

Figure C.16: Option 27 Jumper Locations

C.15 Option 28: Power System Time, Frequency and Phase Monitor

C.15.1 General Description

This document describes Option 28 Power System Time, Frequency, and Phase Monitor, which is used in the Arbiter Systems line of standard Satellite-Controlled Clocks.

C.15.2 Discussion

Option 28 provides the clock with the ability to accept either a 50 Hz or 60 Hz, 30-300 Vrms signal input and measure the instantaneous phase, magnitude and frequency of the fundamental component while rejecting the effects of harmonics, noise and DC offsets. This option also integrates total time deviation, which is system time minus GPS time. Measurement results may be output via the rear-panel RS-232 connector or displayed on the front panel. To determine phase shift across a transmission line, the measured phase angles from two units placed at the ends of the line are subtracted and normalized into the range of 0-360 (or ± 180) degrees. By subtracting the two measurements of absolute phase, which are measured using the same (GPS time) reference, the reference cancels leaving the phase angle between the two units: $A-B = (A-R) - (B-R)$.

C.15.3 System Reference Connection

To connect the Option 28 board to the system reference input perform the following steps:

1. Connect System Reference (50 or 60 Hz signal) input to the Option 28 assembly, using the 6 m (20 ft.) length of twin axial cable provided. Strip the unterminated end of this cable and prepare it as required for termination to your System Reference signal. Do not connect the shield of the cable at the reference input end.
2. Attach this cable to the Option 28 System Reference input. Hold the cable connector by its body (not by the rotating locking ring) and rotate it inside the twin-BNC connector until you feel it begin to mate with the twin-BNC input of the Option 28 assembly. Once the connectors begin to mate, then use the locking ring to secure the connectors together.

NOTE: The supplied cable is terminated at one end with a twin-BNC connector which mates with the system reference input of the Option 28 board.

CAUTION: The twin-BNC connector, unlike a standard BNC connector, will only mate properly in one orientation, and any attempt to force the connector into position with the locking ring when it is improperly oriented (as may be done with standard BNC connectors) will not work, and may damage the connector.

C.15.4 Firmware Configuration

Apply power and observe front panel display, when the clock indicates "CLOCK STATUS STARTUP," press the SETUP key.

Navigate through the series of menu selections, using either the DOWN, UP or SETUP key, until "SET OPTION BOARD?" appears.

Press ENTER, and then press the UP key until Option 28 is displayed. Press ENTER. You will be given additional setup choices for Option 28; Set System Time Dev?, Set UTC/Local Time, Set 50/60 Hz Input, and Return to Main Menu. Select the desired choices. When complete (if this is the first time these options have been activated), turn the clock OFF and back ON again to initialize the Option Boards.

View the deviations on the front panel display as follows:

1. To view the System voltage and phase angle, press the EVENT/DEVIATION key on the front panel:

```
System Input 114.91 V
Phase 359.60°
```

2. To view ΔF and ΔT , press the EVENT/DEVIATION key a second time:

```
System  $\Delta F$  -0.0010 Hz
 $\Delta T$  +0.0000 Sec
```

3. To view System frequency and time, press the EVENT/DEVIATION key a third time:

```
System Frq 59.993 Hz
Time 19:39:25.4327
```

NOTE: Selection of Option 28 results in the deactivation of the Event front panel displays. The event displays may be re-enabled if desired, by entering the SET EVENT/DEVIATION menu and following the procedure below. This choice is only available when Option 28 is installed in the unit.

4. Use the SETUP key and access the SET EVENT DEVIATION? setup menu. Press ENTER to display the following:

```
DISPLAY OPT 28 ONLY?
UP = YES DOWN = NO
```

5. To view Option 28 only, press the UP key, then press the front panel key EVENT/DEVIATION to display Option 28 measurement information.

6. To enable Event/Deviation A and B displays as well, press the DOWN key and configure the Channel Mode, Time, and Recorder Channel. Then press the front-panel key EVENT/DEVIATION to sequentially display all three channels. For a detailed description, refer to Section 5.3.

C.15.5 Calibration

The clock is now configured for operation. Calibration for phase and amplitude are not necessary for most applications, however if necessary, can be performed. Specifically, these calibrations have no effect on system time and frequency measurements, and are unnecessary if only time and frequency are required.

Uncalibrated phase accuracy is usually less than 0.3 degree, and can be reduced to 0.1 degree typical and 0.2 degree guaranteed with calibration. Uncalibrated amplitude accuracy is usually less than 1%, which is the typical performance of this measurement. Amplitude accuracy is not guaranteed, and amplitude measurements are provided primarily to verify that the unit is properly connected and receiving the expected signal level.

C.15.6 Phase Calibration

The factory performs phase calibration, and supplies the calibration factor with the assembly. To be effective, it must be entered into the clock non-volatile memory. Entering this factor into the clock requires connecting the clock to a computer or terminal via the RS-232 interface (see clock manual). For the computer, use a terminal-emulation program such as Procomm or Windows Terminal. Send the character “V” to the clock to check that connections and port settings are correct. The clock should respond with the firmware dates in the format “01 Jan 1997 Op28 02 Jan 1997.”

To send the phase calibration factor to the clock, key in the message:

dd.dd,1084PC, or dd.dd,1088PC, or dd.dd,1093PC

Where dd.dd is the calibration factor in degrees, for example “-0.16”; and 1084, 1093 or 1088 is the clock model number (a security key to prevent unintentional modification):

-0.16,1084PC

C.15.7 Amplitude Calibration

For amplitude calibration, the format is similar, replacing “PC” with “RV”. The calibration factor (supplied with boards having a serial number with prefix greater than 97420) is approximately 1.0, and is multiplied by the measured result to generate the displayed value. If an accurate ac source at 50 or 60 Hz is available (for example, the Arbiter Systems, Inc. Model 1040C Panel Meter Calibrator), the error (for boards with prefix 97420) can be measured and the correction factor entered as described. For example, if applying 120 Vrms to the Option 28 assembly, and the display indicates 119.1 Vrms, the calibration factor is $(120.0 / 119.1)$ or 1.0076. You would enter “1.0076,1084RV” to calibrate the unit (model 1084B/C). The display should then read close to 120.0 Vrms. To clear the calibration factor, you may set the unit to factory defaults or send the command “1,1088RV.” Again, use either 1084, 1088 or 1093 to match the clock model number.

C.15.8 Option 28 Firmware Setup Procedure

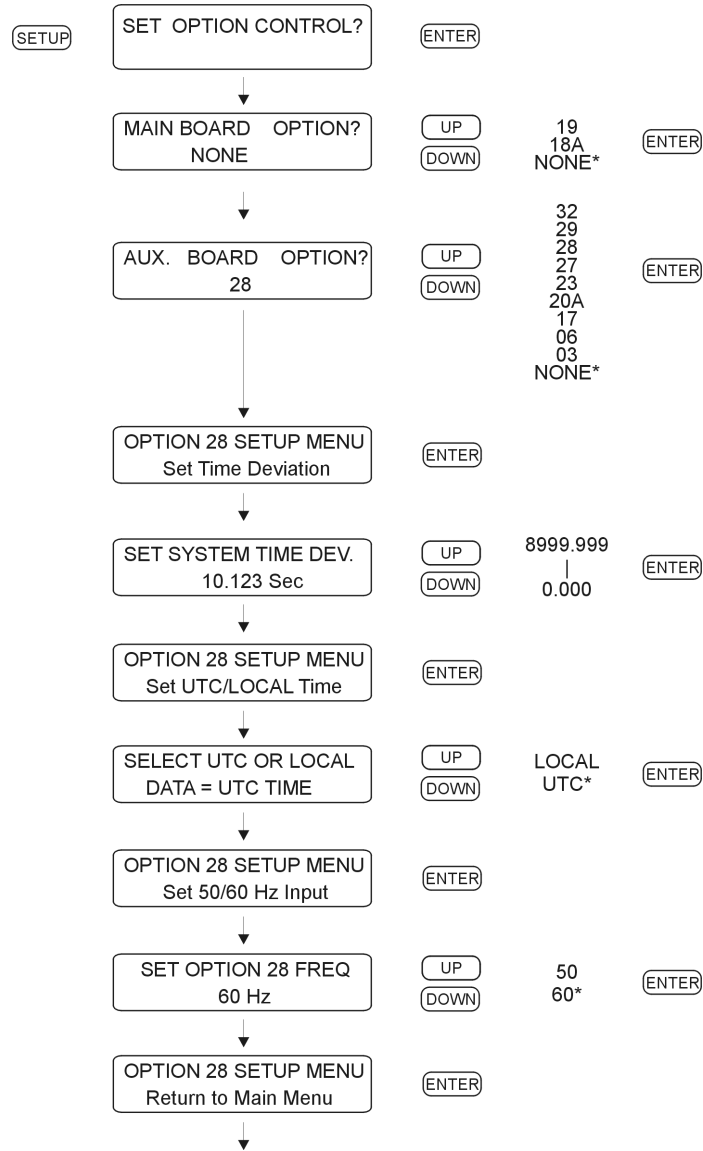

Figure C.17: Option 28 Firmware Setup Procedure

C.15.9 Option 28–Specific RS-232 Commands

The following symbols and syntax are used throughout the RS-232 Commands listing and are repeated here for emphasis:

| | |
|-----|---|
| ▷ | Shorthand for Carriage–Return, Line–Feed. |
| “A” | Channel A. |
| “B” | Channel B. |
| “U” | UTC Time, Channel A (or B). |
| “L” | Local Time, Channel A (or B). |

Fourteen (14) new RS-232 commands are available with Option 28. The following conventions apply to all RS-232 communications:

- Phase angle, in all messages, is defined as zero (or 360) for the positive-going zero crossing coincident with 1 PPS-GPS, and is scaled between zero and 360 degrees. Phase angle increases with frequency below nominal (50 or 60 Hz) and decreases with frequency above nominal; in other words, if the zero crossing occurs just after 1 PPS-GPS, the phase angle will be just above zero, and if the zero crossing occurs just prior to 1 PPS-GPS, phase angle will be just under 360.
- Time deviation decreases (becomes more negative) with frequency below nominal, and increases (becomes more positive) with frequency above nominal.

C.15.10 Option 28 Commands

Return System Frequency

Command: **FS**

“FS” returns Option 28 system frequency.

Response: SS ff.fff >

Where: SS = UTC seconds
ff.fff = frequency

Return System Frequency Deviation

Command: **FD**

“FD” returns the system frequency deviation.

Response: SS±f.fff >

Where: SS = UTC seconds

f.fff = frequency

Return System Phase

Command: **PS**

“PS” returns the system phase.

Response: SS±ppp.pp >

Where: SS = UTC seconds

ppp.pp = phase, 0 to 360 degrees

Return System Time Deviation

Command: **TD**

“TD” returns the system time deviation.

Response: SS±tt.tttt >

Where: SS = UTC seconds

tt.tttt = time deviation

Return System TimeCommand: **TS**

“TS” returns the Option 28 system time.

Response: MM DD YYYY hh:mm :ss.ssss SS >

| | | |
|--------|--------------------|---------------------|
| Where: | “MM” = Month | “mm” = minute |
| | “DD” = Day of Year | “ss.ssss” = seconds |
| | “YYYY” = Year | “SS” = UTC seconds |
| | “hh” = hour | |

Set Option 28 System Time, UTCCommand: **SU**

“SU” sets the Option 28 to reflect system time in UTC format.

Response: >

Set Option 28 System Time, LocalCommand: **SL**

“SL” sets the Option 28 to reflect system time in UTC format.

Response: >

Return System StatusCommand: **SM**

“SM” returns the Option 28 system status.

Response: h >

| | |
|------------|---|
| Where (h): | 0 = System OK |
| | 1 = No System Reference |
| | 2 = System okay now but reference lost since last request |

Start Broadcast Mode–VorneCommand: **B2**

“B2” configures RS-232 broadcast mode to support Vorne large format time displays. Data is transmitted ahead of time, and the <BEL> character is transmitted on time. When properly configured, the Vorne display updates simultaneously upon receipt of the first bit of the <BEL> character. Refer to Arbiter Systems Application Note 103 for more information.

| | | |
|-----------|-------------|---------------------|
| Response: | 11nn > | Out-Of-Lock Time |
| 1/second | 44hhmmss > | UTC/Local Time |
| | 22±ff.fff > | Frequency Deviation |
| | 33±s.ss > | Time Deviation* |

| | |
|--------------|------------------|
| 34±sss.sss > | Time Deviation* |
| 66hhmmss > | System Time |
| 77nn.nnn > | System Frequency |
| 88nnn.nn > | System Phase |
| 89nnn.nn > | System Magnitude |
| 55ddd > | Day of Year |
| <BEL> | <BEL> = hex 07 |

The decimal points shown above are not actually transmitted in the data stream, but their position is implied. The displays are configured to show the decimal point in this position.

*Time Deviation is output in two formats in the same data stream: 33±s.ss and 34±sss.sss.

Output for the 33±s.ss format will be +9.bb when the measured value exceeds +9.99 (b = blank). It will be -9.bb when the measured value is less than -9.99.

Output for the 34±sss.sss format will observe the following conventions for out-of-range values and leading blanks. Decimal points are implicit and do not appear in the data stream.

| Time Deviation Range | Format (b=blank) |
|-----------------------------|-------------------------|
| Below -999.99 | -bbb.bbb |
| -999.99 to -100.00 | -sss.sss |
| -99.99 to -10.00 | -bss.sss |
| -9.99 to -0.01 | -bbs.sss |
| +0.00 to +9.99 | +bbs.sss |
| +10.00 to +99.99 | +bss.sss |
| +100.00 to +999.99 | +sss.sss |
| Above +999.99 | +bbb.bbb |

Table C.9: Option 28 B2 Broadcast, Time Deviation Values

Start Broadcast Mode—ASCII

Command: **B7, O7**

“B7” configures the *Standard RS-232* broadcast mode to send Time, Frequency, and Phase Deviation, once per second, in ASCII format. “O7” configures the *Option RS-232* broadcast mode to send Time, Frequency and Phase Deviation, once per second, in ASCII format.

Response: broadcast mode, UTC:
mm/dd/yyyy hh:mm:ssU ss +f.fff +t.tttt ppp.ppp vvv.vv ⤵

broadcast mode, Local:
mm/dd/yyyy hh:mm:ssL ss +f.fff +t.tttt ppp.ppp vvv.vv ⤵

Where:

| | |
|------------|--|
| mm/dd/yyyy | = Date |
| hh:mm:ssU | = Time of Day, UTC |
| (or) | |
| hh:mm:ssL | = Time of Day, Local |
| ss | = Status |
| | first character is Reference Status: |
| | 0 : Locked; |
| | 1 : Unlocked; |
| | second character is clock status per IEEE 1344 |
| +f.fff | signed Frequency Error in Hz. |
| +t.tttt | signed Time Deviation in seconds. |
| ppp.pp | Phase Angle, 0 to 360 degrees. |
| vvv.vv | Line voltage, rms Volts. |

Set Measured System Deviation

Command: **(-)s.fsRD**

“(-)s.fsRD” sets the system deviation.

Response: ⤵

Where: s = 0 to ±2000 seconds
fs = fractional seconds

Set Phase Calibration

Command: **p:kPC**

“p:kPC” sets the phase calibration offset. Phase offset is stored in protected RAM.

Response: ⤵

Where: p = Phase Offset in degrees
k = Security Key (e.g. 1084)

Set Voltage Amplitude Correction

Command: **v:kRV**

“v:kRV” sets the system voltage amplitude correction.

Response: >

Where: v = Voltage correction per unit with 1.000000 equal to no correction.

 k = Security Key (e.g. 1084)

Return Time, Frequency, Phase Deviation with UTC Time

Command: **nPD**

“nPD” returns the System Time, Frequency and Phase Deviation with a UTC time reference, at each issuance of the command.

Response:

(when n = 0) mm/dd/yyyy hh:mm:ssU ss +f.fff +t.tttt ppp.ppp vvv.vv >

(when n = 1) mm/dd/yyyy hh:mm:ssL ss +f.fff +t.tttt ppp.ppp vvv.vv >

Where:

mm/dd/yyyy = Date

hh:mm:ssU = Time of Day, UTC

(or)

hh:mm:ssL = Time of Day, Local

ss = Status (0 = Locked, 1 = Unlocked)

(first character is Reference Status:)

(second character is clock status per IEEE 1344)

+f.fff signed Frequency Error in Hz.

+t.tttt signed Time Deviation in seconds.

ppp.pp Phase Angle, 0 to 360 degrees.

vvv.vv Line voltage, rms Volts.

C.16 Option 29: Four Additional Outputs; Dry Contacts; +25/50 Vdc

C.16.1 General Description

This document describes Option 29: Four Additional Outputs With Dry Contact and +25/50 VDC; which may be used in the Arbiter Systems Models 1084A/B/C, 1088B, and 1093A/B/C GPS Satellite-Controlled Clocks. Option 29 includes six configurable outputs. Four are standard, 5 V CMOS outputs; two are Aromat AQV210E solid-state relays (SSRs). A +25 or +50 VDC supply is available on-board and may be switched by the SSR outputs.

C.16.2 Specifications

General

Connector 16-position, 5 mm Pluggable Terminal Strip. Four 2-position and two 4-position mating connectors provided. The connectors accept wire sizes of 0.25 to 2.5 mm² (AWG 12 to 22). See Table C.11 and Figure C.19 for Connector Configuration.

Digital Outputs

Quantity 4

Type: 5 V CMOS, individually configurable

Rating: +5 V open-circuit, nominal
75 mA peak current, per channel
+3.5 V typical at 75 mA peak current

Available Signals: Jumper selectable to any of the digital signals available from the clock mainframe plus on board generation of 1 PPM and 1 PPH for the 1093 clock models. See Figure C.18 for Jumper location and selections.

Solid State Relay Output

Quantity: 2

Type: Aromat AQV210E solid-state relays, 130 mA AC or DC at 350 V peak.

Rating: Limited to 100 mA DC, 140 Vrms / 180 V peak by the fuse and surge suppression devices.

Timing: Propagation Delay, 90 μ s Nominal, to 50%.
Rise Time, 50 μ s Nominal, 20-80%.

Solid State Relay Output, continued

Power Supply: Individually configurable for 0 VDC, +25 VDC, or +50 VDC.

Available Signals: 1 PPH, 1 PPM, 1 PPS, Programmable Pulse, Locked and Out of Lock.

Pulse Width: Individually configurable for a fixed, 50-ms pulse, or the default width of pulse provided by the clock mainframe.

Available Configurations:

1. Dry contact closure.
2. Contact closure to ground.
3. +25/50 VDC switched for grounded load
4. +25/50 VDC with contact closure to ground for non-grounded load.

See Table C.10: Operating Modes of SSR Outputs.

| Mode | SSR Output 1 | SSR Output 2 |
|--------------------------------------|---|--|
| Dry Contact Closure | Connect load to pins 10 & 11 (polarity not important) | Connect load to pins 14 & 15 (polarity not important) |
| Contact Closure to Ground | Short pins 9 & 10, connect load to pin 11 | Short pins 13 & 14, connect load to pin 15 |
| +25/50 VDC Switched to Grounded Load | Short pins 11 & 12, connect load to pins 9 (-) & 10 (+) | Short pins 15 & 16, connect load to pins 13 (-) & 14 (+) |
| +25/50 VDC Switched to Floating Load | Short pins 9 & 10, connect load to pins 11 (-) & 12 (+) | Short pins 13 & 14, connect load to pins 15 (-) & 16 (+) |

Table C.10: Operating Modes of SSR Outputs

| Pin | Function | Setup Jumpers–Default Settings |
|---------------|---------------|---|
| 1 (Rightmost) | CMOS Output 1 | JMP4: Signal Select Default = 1 PPH |
| 2 | Ground | – |
| 3 | CMOS Output 2 | JMP3: Signal Select Default = 1 PPM |
| 4 | Ground | – |
| 5 | CMOS Output 3 | JMP2: Signal Select Default = Prog. Pulse |
| 6 | Ground | – |
| 7 | CMOS Output 4 | JMP1: Signal Select Default = IRIG-B |
| 8 | Ground | – |
| 9 | Ground | – |
| 10 | SSR Output 1 | JMP5: Signal Select Default = 1 PPM |
| 11 | SSR Output 1 | JMP7: Standard/50ms Default = 50 ms |
| 12 | +25/50 VDC 1 | JMP10: +25/50 VDC Default = 50 VDC |
| 13 | Ground | – |
| 14 | SSR Output 2 | JMP6: Signal Select Default = 1 PPM |
| 15 | SSR Output 2 | JMP8: Standard/50 ms Default = 50ms |
| 16 (Leftmost) | +25/50 VDC 2 | JMP11: +25/50 VDC Default = 50 VDC |

Table C.11: Output Connectors and Setup Jumpers

C.16.3 Firmware Configuration

1. It is necessary to verify the configuration in the Option Setup Menu so Option 29 is recognized.
2. Apply power and observe the front panel display; when it displays “CLOCK STATUS STARTUP,” press the SETUP key.
3. Press the SETUP key until SET OPTION CONTROL? appears.
4. Press ENTER twice so that “AUX. BOARD OPTION” appears. Press the UP key so that the option number indicates “29” and press ENTER.
5. Press any of the upper row of keys to exit the setup menus.

C.16.4 Output Jumper Setting Changes

1. Set Line Power switch to OFF position (if equipped). Disconnect the power cord from rear-panel.
2. Remove rack-mount ears (if equipped) and remove top cover using a T25 Torx driver (4 screws).
3. Locate the appropriate Jumper using Figure C.18 and move the jumper to the desired setting.
4. Replace the top cover and rack-mount ears (if equipped).
5. Connect the power cord to the rear-panel and set the Line Power switch to ON position (if equipped).

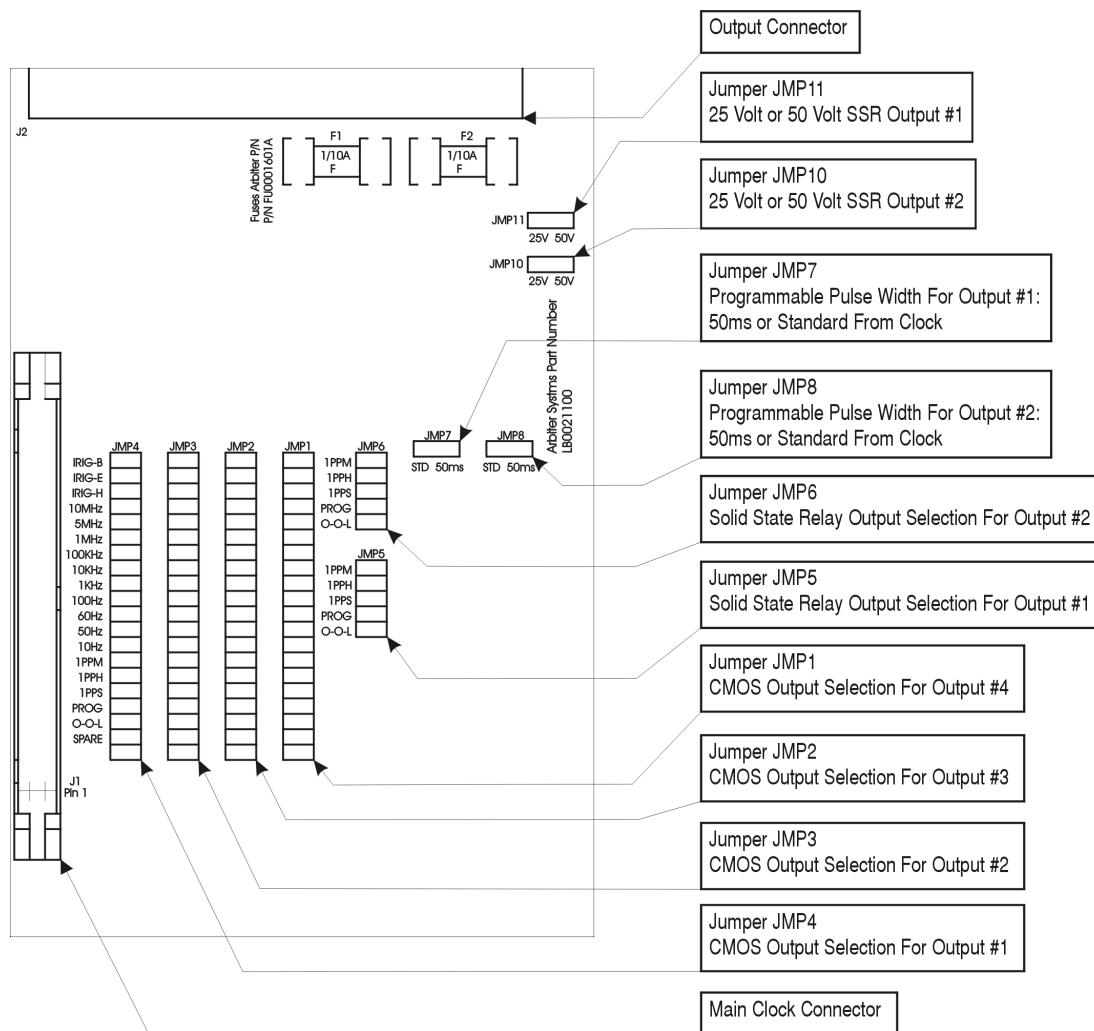

Figure C.18: Option 29 Jumper Locations

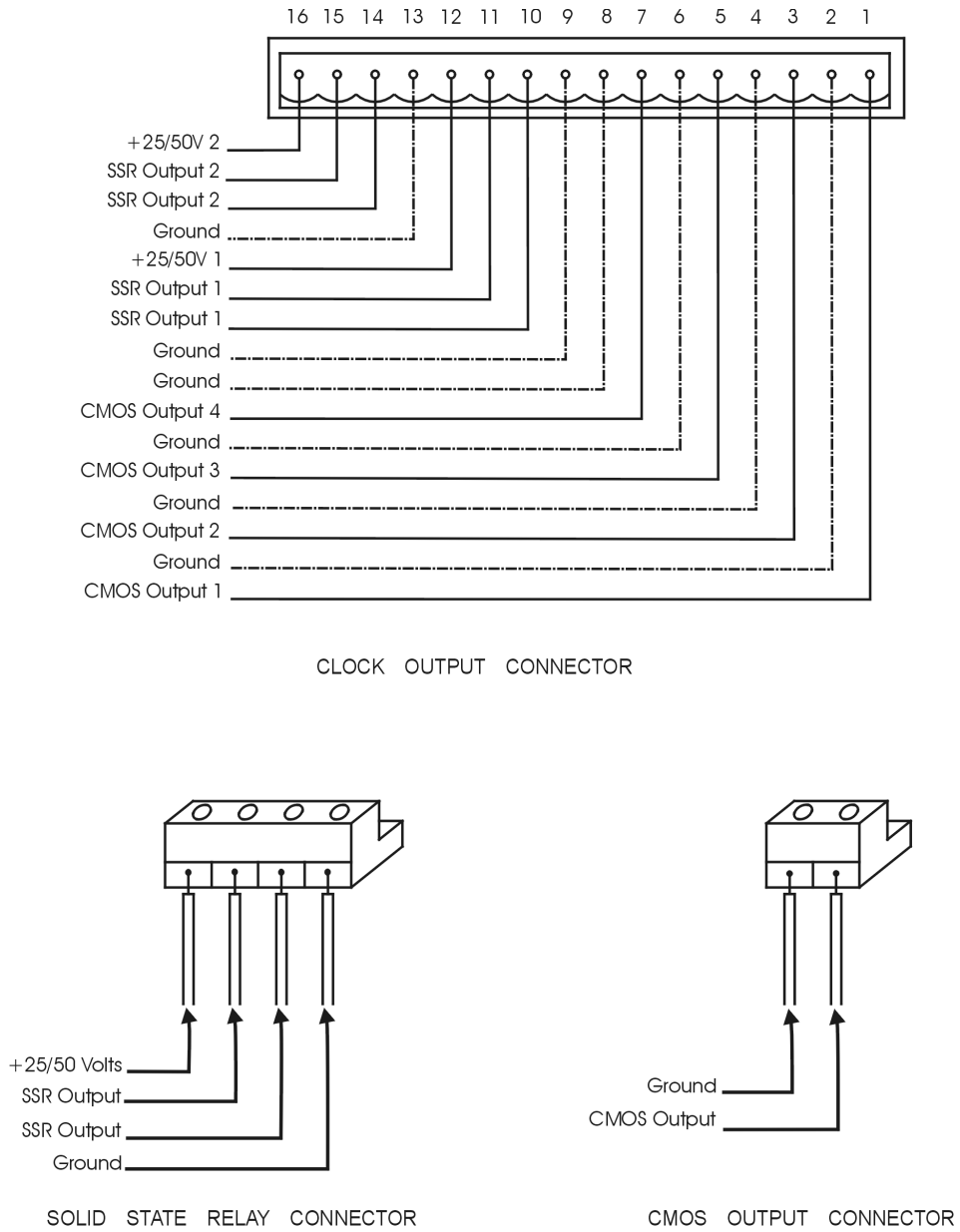

Figure C.19: Option 29 Connector – Signal Locations

C.17 Option 32: Internal NTP Server

C.17.1 General Description

Option 32, Internal Network Time Protocol (NTP) Server, is used in the Arbiter Systems line of 19-inch, rack mount Satellite-Controlled Clocks.

Option 32

Option 32 allows the clock to act as time server over an Ethernet network using the network time protocol operating in server mode - symmetric operation modes are not supported. Time is distributed over the network interface to computers, controllers and other equipment needing the correct time. Option 32 understands NTP Version 1, Version 2, and Version 3 frames, and optionally supports authentication via DES and MD5 cryptographic checksums. If authentication is not used, the controller can typically be used for hundreds of clients without overloading it. Authentication requires typically 40ms for checking and generating the cryptograms, which is covered and averaged out by the protocol. Option 32 supports full SNTP and all NTP functions required for reliable server operation. Functions not required for server operation are not implemented.

Hardware Configuration.

Option 32 consists of two building blocks; an OEM NTP module and an interface to the GPS clock. The NTP Server (Option 32) is connected to the main board via the standard 50 pin option cable. The NTP Server has two external connectors, an RS-232 (DB-9 male) and a 10/100 Base-T (RJ 45). In addition to the connectors there are three status LED's on the rear Panel. See Figure C.20.

External Connectors

The RS-232 connector can be used to interrogate the clock or to configure the NTP module depending on the jumper settings (see Section C.17.2 Jumper Settings). The port parameters are set to 9600, N, 8, 1. This RS-232 port is not operational during normal use. The Ethernet port is used to distribute time and can also be used to configure the NTP module.

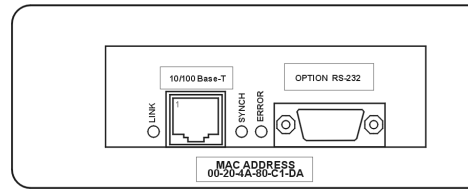

Figure C.20: Option 32 Rear Panel

RS-232

The RS-232 port uses a 9 pin d-sub connector. This connector is configured as a DTE device with the following pin out:

| | |
|----------------|-------|
| Receive (RXD) | Pin 2 |
| Transmit (TXD) | Pin 3 |
| Ground (GND) | Pin 5 |

10/100 Base-T

Option 32 uses the standard 10/100 base-T connection for connecting to an Ethernet. Figure C.20 indicates the location of pin 1.

| | |
|-------|-------|
| Txd + | Pin 1 |
| Txd - | Pin 2 |
| Rxd + | Pin 3 |
| Rxd - | Pin 6 |

Status LED's

There are three status LED's on the rear panel of Option 32. The LED's are Link (green), Synch (green) and Error (red). Option 32 will perform an initial self test when powered on. After the initial self-test phase, where all status LEDs should be lit, the LED's indicate the status of the NTP Server.

Link LED

Link (green) LED on: Ethernet 10/100 base-T connection is good.

Synch LED

Synch (green) LED on: synchronized to the time signal, correct reception of time data, requires the satellite controlled clock to be synchronized.

Synch LED flashing 50% duty cycle: Some information received, but not yet synchronized reliably.

Error LED

If the Error LED is on or blinking the Synch LED will give a diagnostics code.

Error (red) LED stable on, Synch (green) LED flashing

- 1x: EPROM-checksum error
- 2x: RAM-error
- 3x: Network controller error
- 4x: EEPROM checksum error, or is bad
- 5x: IP address already used on network

Error LED flashing, Synch LED flashing

- 4x: Faulty network connection
- 5x: No DHCP response was received

C.17.2 Jumper Settings.

There are three jumpers on Option 32. Jumpers 1 and 2 (JMP1 and JMP2, Figure C.21 and Table C.12) control the serial port. When JMP1 and JMP2 are in position A (top), Option 32 will operate as an NTP Server. Setting JMP1 and JMP2 to the B (middle) allows the clock to be interrogated. Both JMP1 and JMP2 must be placed in position C (bottom) to configure the NTP module via the RS-232 port. Jumper 3 (JMP3) is set according to clock model as described in Table C.13.

| Position | Function |
|----------|---|
| A | Clock connected to the NTP module (default) |
| B | Clock connected to the external RS-232 port * |
| C | NTP module connected to the external RS-232 port. |

Table C.12: JMP1 and JMP2 Settings

*The clock must be configured for the second RS-232 Option 17A (Model 1088B) to allow bi-directional communication.

JMP1 and JMP2 should be in the same position and are required to be in position A for normal operation of Option 32.

| Position | Function |
|----------|--|
| A | For installation in the Model 1088B |
| B | For installation in the Model 1084A/B/C or Model 1093A/B/C |

Table C.13: JMP3 Settings

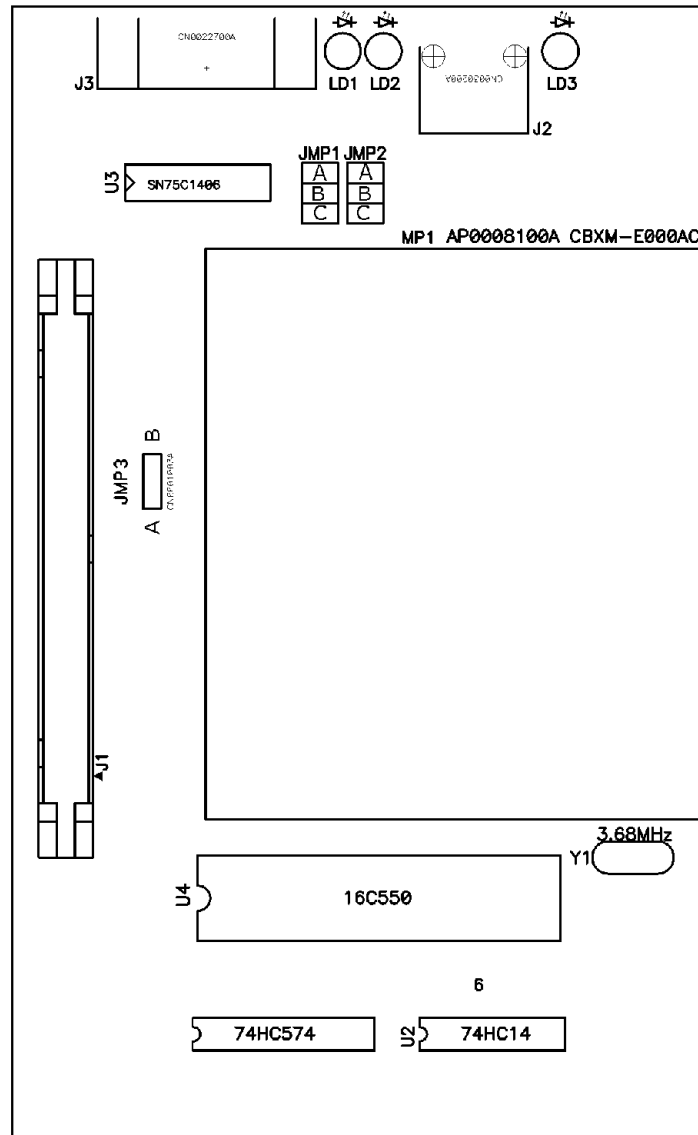

Figure C.21: Option 32 Board–Jumper Locations

C.17.3 Firmware Configuration.

Firmware configuration for the Option 32 is performed in two parts: the first part involves setting the correct option number via the front panel; the second part requires configuring the Ethernet port via the Ethernet port, or the optional RS-232C port on the NTP module.

Front Panel

1. Apply power and observe the front panel display, when CLOCK STATUS STARTUP is displayed, press the SETUP key.
2. Navigate through the series of menu selections, using either the DOWN, UP or SETUP key,

until SET OPTION BOARD? Appears (Slot B for the Model 1088B).

3. Press ENTER, and then press the UP key until Option 32 is displayed. Press ENTER.

NTP Module.

The NTP module can be configured over the Ethernet port or the option RS-232 port. The Ethernet is the preferred port, as no configuration changes are required to use this port.

Ethernet

To configure the NTP module over the network, establish a Telnet connection to port 9999. The default IP number for the Ethernet is 192.168.0.232. If the IP address of the NTP Server (NTS) is unknown or undefined, the following sets a temporary IP address:

a) Set a static ARP with the desired IP address using the hardware address of the NTS, which is printed on the product label. The address can also be calculated from the serial number. Below is the command example for WinNT/WinXP, using the DOS prompt, when the hardware address of the NTS is 00-20-4A-02-64-0B.

```
arp -s 192.168.0.232 00-20-4A-02-64-0B
```

NOTE: In order for the ARP command to work in Windows, the ARP table on the PC must have at least one IP address defined other than its own. Type “ARP A” at the DOS command prompt to verify that there is at least one entry in the ARP table. If there is no other entry beside the local machine, ping another IP machine on your network to build the ARP table. This has to be a host other than the machine that you’re working on. Once there is at least one entry in the ARP table, use the listed commands to ARP an IP address to the NTP Server.

The command example for most Unix systems is:

```
arp -s 192.168.0.232 00:20:4A:02:64:0B
```

b) Open a telnet connection to port number 1. This connection will fail, but the NTS will change its IP address to the desired one in that step. **telnet 192.168.0.232 1**

c) Open a telnet connection to port 9999 and set all required parameters.

```
telnet 192.168.0.232 9999
```

NOTE: The temporary IP address is reverted after every power reset of the NTS. Be sure to enter the configuration and store the parameters to make the changes permanent.

Serial

An ASCII terminal or PC with a terminal emulation can be connected to the option RS-232 port, but JMP1 and JMP2 must be set to “C”. The terminal (or PC) should be configured to 9600 Baud, no parity, 8 data-bits, 1 stop-bit. The power must be cycled to enter the configuration mode. The self-test begins after power-up. About a half-second later the Error (red) LED starts blinking. Now send three lowercase “x” characters to the NTP Server. These characters must all be sent within one second to start configuration mode.

NOTE: The easiest way to enter configuration mode is to hold down the “x” key at the terminal (emulation) and then powering the NTP Server. This will ensure that the x characters will arrive in time.

C.17.4 General Configuration

After configuration mode is entered (confirm with <CR>), the parameters can be changed; default values can be confirmed with the enter key. When leaving the setup mode after selecting function 9 all parameters are stored in a nonvolatile memory and the NTP server resets.

Basic Parameters

To change the basic parameters, type “0.” The following values can be set/changed:

Ethernet Interface: Set to (N).

IP Address: The IP address must be set to a unique value in your network. If the NTP Server is set to an address, which is already in use, it will display an error code with the LEDs (see “LED Status”) and will not connect to the network.

Gateway IP Address: The router/gateway address is needed to communicate to other LAN segments. The default gateway must be set to address the router that connects these segments. This address must be within the local network. If in doubt, consult the network administrator.

Netmask: A netmask defines how many bits from the IP address are to be taken as the network section and how many bits are to be taken as the host section (reminder: Standard class A 8/24 (net/host), class B 16/16, class C 24/8 bits). If set to 0, the standard appropriate netmask for the actual IP address is used. The NTS prompts for the number of host bits, and then calculates the netmask. It is shown in standard format “255.255.xxx.xxx” when parameters are displayed.

Telnet Config Password: The Telnet configuration password can be set to disable unauthorized access to the setup menu through a Telnet connection to the setup port (9999). For the setup through the serial port, it is not necessary to enter the password. The controller can be configured over a Telnet connection to port 9999 (assuming the network parameters are set correctly and the NTS is connected to the network).

C.17.5 NTP Server Parameters

The network operations of the server are controlled by various parameters.

Antenna Type: Set type to 6=GPS/Arbiter

UDP-Port: The UDP port selects the port number for the NTP proprietary protocol.

Send Block Every n Minutes: This parameter determines how often the data block should be sent.

Send UDP-Broadcast: If the time information should be sent to all devices connected to this LAN (broadcast), set this parameter to “Y” = yes.

UDP-Target Address: This parameter determines the target addresses to which the data block should be sent. The data block can be sent over a Gateway or other devices to another part of the network. The maximum number of defined addresses is eight. NTP and UDP/time port numbers are fixed to the values defined in RFC-37 and RFC-123 respectively. If the authentication option is enabled, up to seven MD5 or DES keys can be entered (key numbers 1..7). All key input must be done in hexadecimal format; MD5 key length is limited to eight characters.

When leaving the setup mode after selecting function 9 all parameters are stored in a nonvolatile memory and the NTP server resets. Select 8 to exit without saving modifications.

Appendix D

CE Mark Certification

D.1 Introduction

On the following pages contain the individual CE Mark Certifications for models covered in this manual. This includes Model 1084A, 1084B, 1084C.

Declaration of Conformity with European Union Directives

Date of Issue: June 30, 2003

Directives: 89/336/EEC Electromagnetic Compatibility
73/23/ EEC Low Voltage Safety

Model Number(s): 1084A GPS Satellite-Controlled Clock

Manufacturer: Arbiter Systems, Inc.
1324 Vendels Circle, Suite 121
Paso Robles, CA 93446 – USA

Harmonized Standard Referenced: EN55011 Class A, Radiated and Conducted Emissions
EN50082-1 Generic Immunity, Part 1
Residential, Commercial and Light Industrial Environments
EN61010-1 Safety requirements of Electrical Equipment for
Measurement, Control and Laboratory Use.

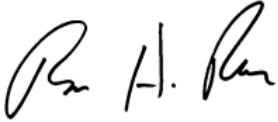
Signed: 

Signatory: Bruce H. Roeder

This certificate declares that the described equipment conforms to the applicable requirements of the directives on Electromagnetic Compatibility 89/339/EEC, Safety 73/23/EEC, and amendments by 93/68/EEC adopted by the European Union.

Declaration of Conformity with European Union Directives

Date of Issue: June 30, 2003

Directives: 89/336/EEC Electromagnetic Compatibility
73/23/ EEC Low Voltage Safety

Model Number(s): 1084B GPS Satellite-Controlled Clock

Manufacturer: Arbiter Systems, Inc.
1324 Vendels Circle, Suite 121
Paso Robles, CA 93446 – USA

Harmonized Standard Referenced: EN55011 Class A, Radiated and Conducted Emissions
EN50082-1 Generic Immunity, Part 1
Residential, Commercial and Light Industrial Environments
EN61010-1 Safety requirements of Electrical Equipment for Measurement, Control and Laboratory Use.

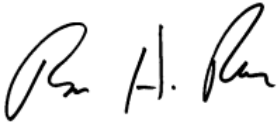
Signed: 

Signatory: Bruce H. Roeder

This certificate declares that the described equipment conforms to the applicable requirements of the directives on Electromagnetic Compatibility 89/339/EEC, Safety 73/23/EEC, and amendments by 93/68/EEC adopted by the European Union.

Declaration of Conformity with European Union Directives

Date of Issue: June 30, 2003

Directives: 89/336/EEC Electromagnetic Compatibility
73/23/ EEC Low Voltage Safety

Model Number(s): 1084C GPS Satellite-Controlled Clock

Manufacturer: Arbiter Systems, Inc.
1324 Vendels Circle, Suite 121
Paso Robles, CA 93446 – USA

Harmonized Standard Referenced: EN55011 Class A, Radiated and Conducted Emissions
EN50082-1 Generic Immunity, Part 1
Residential, Commercial and Light Industrial Environments
EN61010-1 Safety requirements of Electrical Equipment for Measurement, Control and Laboratory Use.

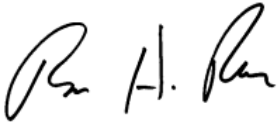
Signed: 

Signatory: Bruce H. Roeder

This certificate declares that the described equipment conforms to the applicable requirements of the directives on Electromagnetic Compatibility 89/339/EEC, Safety 73/23/EEC, and amendments by 93/68/EEC adopted by the European Union.

Appendix E

Statement of Compliance

E.1 Introduction

The following page is a statement of compliance that includes Model 1084A, 1084B, and 1084C.

G.P.S. Satellite Clock Statement of Compliance

February 5, 2008

TO WHOM IT MAY CONCERN:

All Arbiter Systems, Incorporated G.P.S. Satellite Controlled Clocks are Primary Standards. They provide time traceable to U.T.C. and U.S.N.O. within published accuracy specifications anywhere in the world. All Arbiter Systems Incorporated G.P.S. Satellite Controlled Clocks also carry a limited lifetime warranty, which is based on in field MTBF (Mean Time Between Failures) of over one million (1,000,000) hours. These products are available with all known time synchronization signals presently in use world wide by the electric power industry.

Arbiter Systems does not supply a type test certificate as requested for G.P.S. systems as the accuracy is a function of the G.P.S. system and not of the receiver. However we (Arbiter) hereby certify that this equipment conforms to all Arbiter Systems Incorporated specifications for material and process. All Arbiter Systems calibration products are supplied with a type test certificate guaranteeing traceability to National Standards, but are inappropriate for G.P.S. clocks, which are Primary Standards by definition.

Regards,

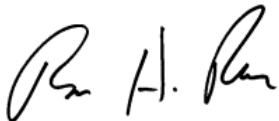
A handwritten signature in black ink, appearing to read "Bruce H. Roeder". The signature is fluid and cursive, with the first name "Bruce" being the most prominent.

Bruce H. Roeder
International Marketing Manager
Arbiter Systems, Inc.
BHR/sc

Index

- 1-PPS
 - description, 55
- accessories
 - antenna & cable, 22
 - included, 1
- altitude, see elevation display
- amplifier
 - antenna cable, 22
- analog drivers, 52
- antenna
 - clock connection, 23
 - connection, 17, 23
 - installation, 17
 - mounting assembly, 18
 - mounting kit, 17, 18
 - mounting procedure, 17
 - power supplied to, 23
 - resistance, 20
 - surge protector, 20
 - user-supplied cables, 23
 - voltage, 20
- antenna & cable testing, 20
- antenna cable
 - attenuation, 21
 - DC resistance, 22
 - delay, 21
 - details, 21
 - effects of cable parameters, 21
- Appendix
 - A, 95
 - B, 103
 - C, 105
 - D, 175
 - E, 179
- cable
 - accessory, 22
 - adjacent signal interference, 23
 - delays, 58
 - distance, 56
 - physical protection, 22
 - timing output, 55
 - user-supplied, 23
 - wire losses, 57
- CE mark certifications, 175
- chapter list, v
- comm ports, 65
- command key
 - definitions, 6
- configure
 - begin, 30
 - firmware setup, 29
 - settings
 - auto survey, 48
 - back light, 37
 - broadcast, 33
 - daylight saving time, 35
 - event/deviation, 47
 - irig time data, 46
 - local hour, 34
 - option control, 50
 - out of lock, 36
 - port parameters, 33
 - programmable pulse, 39
 - RS-232, 32
 - system delays, 38
- connecting
 - modulated IRIG-B, 57
 - outputs, 55
 - unmodulated IRIG-B, 57
- connecting power to the clock, see inlet power
- connector
 - antenna, 9, 17
 - event input, 9
 - power inlet, 8
 - relay contacts, 10

- serial communications, 10
- timing output, 10
- contact information, ii
- copyright, v
- cordsets
 - IED-320 power inlet connector, 12
- crimp tool
 - RG-11, 22
- digital drivers, 52
- display
 - startup, 90
- display modes
 - Position, 94
 - Time, 92
- drive current vs. output voltage, 53
- driver
 - analog, 52
 - digital, 52
- elevation display, 94
- event display indication, 91
- event trapping, 64
 - arming, 64
- fault indication
 - serial port, 68
- fault modes, 92
- firmware
 - updates, ii
- front panel drawing, see panel drawing, front
- fuses
 - replacing, 14
 - types and location, 14
- handling
 - precautions, 1
- IEC-320 connector, see Option, 07
- initial clock time, 89
- initial LED indication, 89
- initial startup sequence, 89
- inlet power, 12
- IRIG-B
 - IEEE 1344 description, 55
 - initial indication, 92
 - modulated
 - voltage matching, 58
 - timecode description, 54
 - type codes, 54
 - unmodulated, 54
 - waveform comparison, 54
- IRIG-B Time code types, 53
- issuance, ii
- keys
 - description, 7
 - Down, 8
 - Enter, 8
 - Event/Deviation, 8
 - Position, 8
 - Setup, 8
 - Status, 8
 - Time, 8
 - Up, 8
- latitude display, 94
- LCD
 - display, 7
- LED
 - annunciator
 - definitions, 6
 - status indicators, 7
- longitude display, 94
- mounting kit
 - antenna, 17
- numeric data entry mode, 31
- Option
 - 08, terminals with SWC, 9
 - 10, terminals with SWC, 9
 - power, 07, 12
 - power, 08, 13
 - power, 10, 13
- Options List
 - Option 01, Backlight, 106
 - Option 02, Battery Backup, 107
 - Option 03, Four Additional Outputs, 108
 - Option 04, ON/OFF Switch, 113
 - Option 07, IEC-320 Power Inlet, 125
 - Option 08, 10 – 60 Vdc Power Inlet, 126
 - Option 10, 110 – 370 Vdc Power Inlet, 127
 - Option 19, Second RS-232 Port, 140
 - Option 20A, Four Fiber Optic Outputs, 141

- Option 23, COMTRADE Sample Rate Generator, 144
- Option 27, 8-Channel High Drive, 151
- Option 28, Power System Time, Frequency and Phase Monitor, 153
- Option 29, Four Outputs, Dry Contacts, 163
- Option 32, Internal NTP Server, 168
- output signal
 - description, 53
- panel
 - rear
 - description, 52
- panels
 - drawing
 - front, 5
 - rear, 8
 - front, 5
 - rear, 5
- position display modes, 94
 - datum, 94
- power supply
 - voltage, 20
- programmable pulse
 - description, 55
 - pulse width, 55
- rack mount
 - mounting instructions, 2
- rear panel, see panel, rear
- RG-11
 - cable, 22
 - crimp tool, 22
- ROM date, ii
- serial command
 - antenna delay
 - set, 86
 - arm event trigger, 72
 - backlight auto, 79
 - backlight off, 78
 - backlight on, 79
 - broadcast ASCII + Quality, 69
 - broadcast ASCII Std, 67
 - broadcast Event Data, 68
 - broadcast Extended ASCII, 69
 - broadcast NMEA183 GLL, 70
 - broadcast NMEA183 ZDA, 71
 - broadcast Status, 68
 - broadcast strings, 67
 - broadcast Vorne Std, 67
 - broadcast Year + ASCII, 70
 - broadcast, interrogate, 67
 - clear event buffer, 72
 - clock offset
 - set, 86
 - Configure Option 23, 146
 - DST/Summertime
 - activate, 77
 - return settings, 77
 - start time, 77
 - stop time, 77
 - enable front panel, 78
 - Event
 - channel time, 71
 - return deviation, 72
 - Event number, 71
 - front panel, disable control panel, 78
 - Local Offset, 78
 - lock setup keys, 78
 - Opt28
 - commands, 158
 - Option 28
 - return System status, 159
 - return time, freq, dev, UTC, 162
 - set deviation, 161
 - set phase calibration, 161
 - set System time as Local, 159
 - set System time as UTC, 159
 - set voltage correction, 162
 - start Broadcast ASCII, 161
 - start Broadcast Vorne, 159
 - system frequency, 158
 - system frequency deviation, 158
 - system phase, 158
 - system time, 159
 - system time deviation, 158
 - out-of-lock alarm
 - set time, 86
 - Prog Pulse
 - pulse polarity, 85
 - set pulse width, 84
 - set time mark, 85

- Pulse Per Hour, 84
- Return
 - display buffer, 86
 - elevation, 80
 - firmware version, 86
 - latitude, 81
 - local date, 83
 - local time, 83
 - longitude, 81
 - UTC date, 83
 - UTC time, 83
- Seconds per Pulse, 84
- Set deviation operation, 71, 72
- set elevation, 80
- Set event operation, 72
- set IEEE 1344 mode, 79
- set latitude, 80
- set local time, 79
- set longitude, 80
- set receiver time, 83
- set UTC time, 79
- Status
 - clock, 73
 - EEPROM, 74
 - receiver, 74
 - status of event/deviation, 73
 - survey, 75
 - system, 75
 - time quality, 76
- survey mode, 82
- serial port
 - output symbols, 66
 - pin definitions, 88, 99
- Setup menu list, 30
- signal
 - output
 - description, 53
- startup sequence, 89
- Statement of Compliance, 179
- status display indication, 91
- support
 - request, iii
- synchronizing
 - multiple devices on one port, 56
- time display modes, 92
- timing outputs
 - description, 52
 - intro, 51
- title page, v
- unpacking the clock, 1
- version
 - manual, v
- warranty, iii